



Products At A Glance

2 - 3

Introduction & Ordering Data

4 - 7

Synchronous Motors

8 - 21

Stepper Motors

22 - 30

Reduction Gearheads

31 - 51

DC Geared Motors

52 - 56

Characteristic features of MECHTEX synchronous motors

- ▲ For Coil $\geq 42V$ AC, 2kV & For Coil $\leq 42V$ AC, 0.6 kV/50 Hz insulation voltages between coil and housing for 1 min.
- ▲ Life expectancy in continuous operation 3...10years.
- ▲ UL marking (on request)/ CE marking (on request)/ RoHS compliant.
- ▲ Maintenance-free Polyacetal / Self-lubricating sintered bronze bushings or ball-bearings.
- ▲ Wide operating range in the case of reversing synchronous motors.
- ▲ Stall protection in most MECHTEX motors (except S2 duty cycle motors)
- ▲ Each motor is subjected to final inspection.
- ▲ Special windings for intermittent operations (marked x & y)

Characteristic features of MECHTEX Reduction Gears

- ▲ 12 series with a gear torque range from 0.3 Nm to 30 Nm
- ▲ Wide range of transmission ratios from $i = 2$ to 3,780,000
- ▲ All gears are permanently lubricated and therefore maintenance-free
- ▲ Motor and gear are linked by snap-on clips, screw clip or screws mounting.
- ▲ Various output shaft options available as standard.
- ▲ Easy mounting by means of two, three, four or six fastening screws
- ▲ Optional mounting position (output shaft preferably horizontal)

Description

Series of Motor
see page 5

Approvals
N Standard
C CE marked
U UL marked
X other approvals

Supply Voltage
see page 5

Mounting Assessories
N Snap clip
S Screw Clip
P mounting plate
T internal screw mounting

Reduction gear series
see page 6

Gear ratio
page 6 & 7

Output shaft
S standard output
 For other shaft type or special output shaft see details of the individual reduction gear series

Sense of rotation of shaft
 (view gear side with motor facing away)
C clockwise rotation
A anticlockwise rotation
R reversible rotation

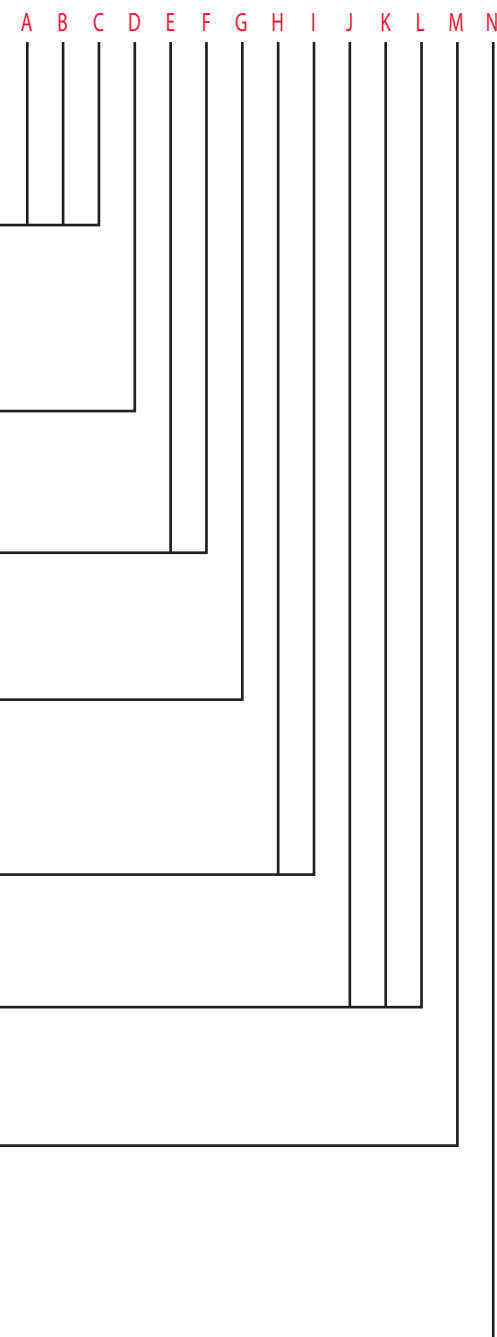

Order Specifications For Motor /Gearhead Combinations

One may select specific motor or gearhead or its combination. The data given as under :

Motor Ordering Data

Series of Motors

Motor 1st digit	Motor 2nd digit	Motor 3rd digit
0 AC Synchronous motor	Motor Series	Variable
1 Unipolar Stepper motor		
2 Bipolar Stepper motor		

MT0	MT6	MTR2b	MTR3a	MTR3b	MTR5	MTR4a	MTR4b
00C	06F	02B	03A	03B	05B	04A	04B
		12B	13A	13B	15B	14A	14B
		22B	23A	23B	25B	24A	24B

MTR4b-RE	MTRD4b	MTRD4b-RE	MTR7a	MTR8c	MTR8c-RE	MTR9a	MTR9b	MTR9d
04C	04D	04E	07A	08C	08E	09A	09B	09D
14C	14D	14E	17A					
24C	24D	24E	27A	28C	28E			

DC28	DC30	DC32	DC38	DC42	DC52
A28	A30	A32	A38	A42	A52
B28	B30	B32	B38	B42	B52
L28	M30	M38	M42	M52	
Q28					
W28					

Supply Voltage

A1	220 50Hz	B3	110-y 50 Hz	E1	240 50Hz	G1	48 50Hz	D1	24 V DC
A2	220-x 50 Hz	B4	110 60Hz	E2	240-X 50 Hz	G2	48-x 50 Hz	D2	12 V DC
A3	220-y 50 Hz	B5	110-x 60 Hz	E3	240-Y 50 Hz	G3	48-y 50 Hz	D3	6 V DC
A4	220 60Hz	B6	110-y 60 Hz	E4	240 60Hz	G4	48 60Hz	D4	3 V DC
A5	220-x 60 Hz	C1	24 50Hz	E5	240-X 60 Hz	G5	48-x 60 Hz	D5	18 V DC
A6	220-y 60 Hz	C2	24 x 50Hz	E6	240-Y 60 Hz	G6	48-y 60 Hz	D6	9 V DC
B1	110 50Hz	C4	24 60Hz	F1	12 50Hz	XX	OTHER NON STANDARD	D7	4.5 V DC
B2	110-x 50 Hz	C5	24 -x 60Hz	F4	12 60Hz			DX	OTHER NON STANDARD

Motor Series **MT0**



Uni-Directional Synchronous Motor - 375 RPM

Application

Timers, Chart recorders, Potentiometer Drives, light Displays, Hour Meters, Cam Timers, Programming devices and control instrumentation.

Design

MT0 is a unidirectional motor with a cylindrical sheet-iron stator in which the field poles form the stator ring. In combination with the auxiliary poles (provided with copper shading rings) a rotating field is generated when the coil is energized.

The rotor turns in sintered bushings requiring no maintenance. The motor shaft is polished to a mirror finish. Motor can be provided with screw clip for fixing.

Standard Data

Motor type		Uni directional synchronous; with electrical shading
Ambient temperature operation	°C	-15...+55
Ambient temperature storage	°C	-20...+100
Thermal class	°C	105
Electrical Enclosure	IP	40
Connections		Flexible Leads 26 AWG, 200mm length; ends stripped
Life expectancy		3 years in continuous operation
Mounting		any position
HVT		2.0 KV (motor voltage > 40V) or 0.6 KV (motor voltage < 40V) for 1 min.
Weight	g	100
Rotor stalling		Motor can be stopped when voltage is applied, without being overheated
Rotor shaft		Hardened steel, ground and polished
Bearings		Sintered bronze, self-lubricating
External dimensions		dia. 42 x 18 mm

Technical data

Standard Motor Voltages	V	12, 24, 110, 220 & 240..... (others on request)	
Tolerance of voltage	%	-10....+15% of rated voltage	
Duty cycle	%	100	
Rated frequency	Hz	50	60
Power output at rated voltage	W	0.08	0.07
Speed	rpm	375	450
Running torque at rated voltage	N-cm	0.20	0.16
Power consumption at rated voltage	W	1.4	1.5

Motor Drawing

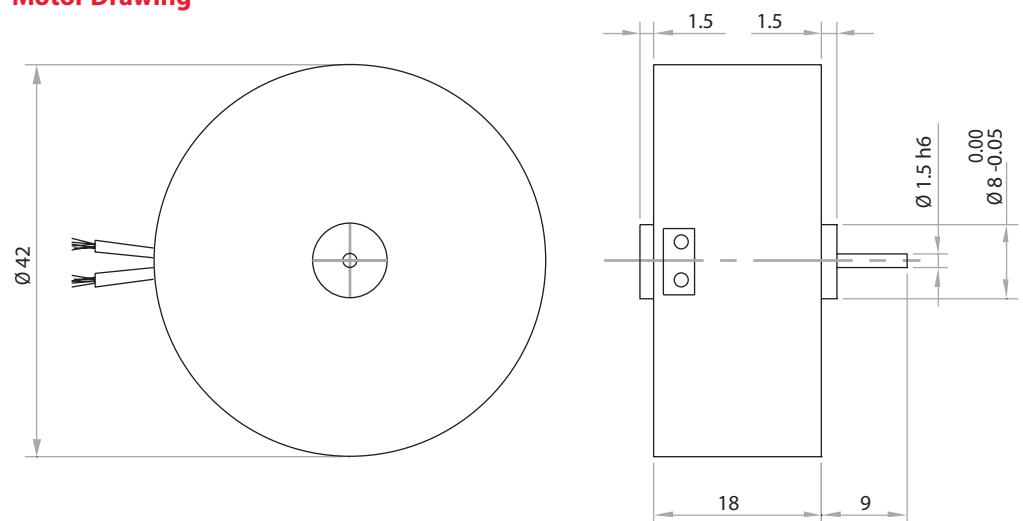

Ordering Data (eg.)

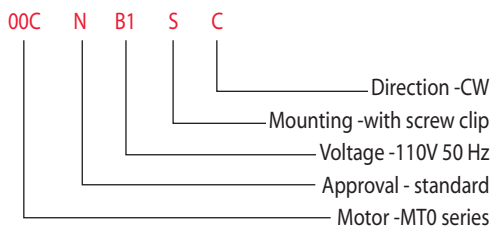

Motor Series **MT6**



Uni-Directional Synchronous Motor - 600 RPM

Application

Instrumentation, diamond machinery, peristaltic pumps, motorised displays, programming devices, cam timers, medical equipment.

Design

MT6 is a unidirectional synchronous motor. The direction of the motor is either cw or ccw which is fixed with help of reversing stopper while manufacturing. This non reversing device also guarantees at all times starting in the desired direction with high starting torque. The motor consists of a cylindrical sheet iron stator which form the poles.

Mounted on the hardened and highly polished rotor shaft is a high coercivity sintered magnet ring around whose circumference 10 poles of alternate polarity are disposed. Special version of motor without the non reversing device is also available. In this case the motor can start in any direction. Motor can be provided with screw clip for fixing.

Standard Data

Motor type		Uni directional synchronous; with mechanical anti return device
Ambient temperature operation	°C	-15...+55
Ambient temperature storage	°C	-20...+100
Thermal class	°C	105
Electrical Enclosure	IP	40
Connections		Flexible Leads 26 AWG, 200mm length; ends stripped
Life expectancy		3 years in continuous operation
Mounting		any position
HVT		2.0 KV (motor voltage > 40V) or 0.6 KV (motor voltage < 40V) for 1 min.
Weight	g	132
Rotor stalling		Motor can be stopped when voltage is applied, without being overheated
Rotor shaft		Hardened steel, ground and polished
Bearings		Poly Acetal
External dimensions		dia. 47 x 22.5 mm

Technical data

Standard Motor Voltages	V	12, 24, 110, 220 & 240.....(others on request)	
Tolerance of voltage	%	-10...+15% of rated voltage	
Duty cycle	%	100	
Rated frequency	Hz	50	60
Power output at rated voltage	W	0.77	0.87
Speed	rpm	600	720
Running torque at rated voltage	N-cm	0.5	0.5
Power consumption at rated voltage	W	2.5	2.7

Motor Drawing

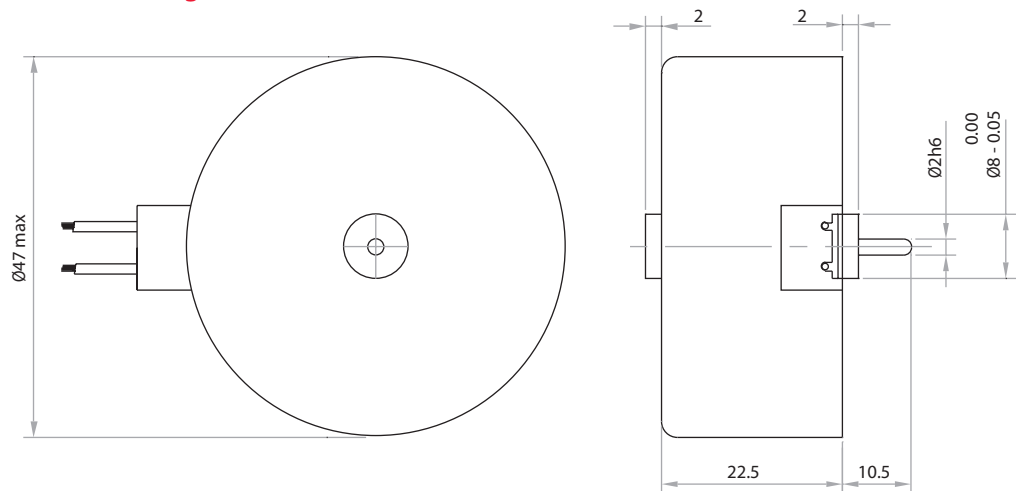

Ordering Data (eg.)

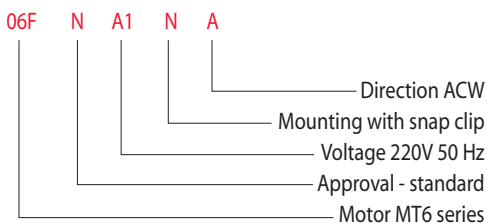

Motor Series **MTR2b**



Reversible Synchronous Motor - 500 RPM

Application

Recorders, Instrumentation, Diamond machinery, Valve Actuators, Light displays, Medical equipment, Air conditioning & refrigeration, Dosing Pumps, Vending machines CCTV Camera positioning, any timing and positioning Application.

Design

MTR2b reversing synchronous motor is of the permanent magnet type with two stator windings, for single phase AC 50/60 Hz. Phase displacement of the excitation current is achieved by connecting a capacitor in series with one of the stator windings. The sense of rotation is determined by the resulting circular rotating field. Electrical reversal of the sense of rotation is effected by means of a single-pole changeover switch The 12 pole rotor which has a steel shaft polished to a mirror-finish rotates in sintered bronze bearings. Motor can be provided with Mounting plate.

Standard Data

Motor type		Reversible synchronous
Ambient temperature operation	°C	-15...+55
Ambient temperature storage	°C	-20...+100
Thermal class	°C	105
Electrical Enclosure	IP	40
Connections		Flexible Leads 28 AWG, 200mm length; ends stripped
Sense of rotation		Indicated by lead colour (red-CW & black ACW)
Life expectancy		3 Years in continuous operation
Mounting		any position
HVT		0.6 KV (motor voltage < 40V) for 1 min.
Weight	g	30
Rotor stalling		Motor can be stopped when voltage is applied, without being overheated
Rotor shaft		Hardened steel, ground and polished
Bearings		Sintered bronze, self-lubricating
External dimensions		dia. 20.4 x 17 mm

Technical data

Standard Motor Voltages (V _N)	V	12	24
Operation capacitor (50 Hz) C _N	µF/VAC	10/20	2.2/40
Operation capacitor (60Hz) C _N	µF/VAC	10/20	2.2/40
Lead colour (V _N)		Grey	Blue
Tolerance of voltage	%	-10...+15% of rated voltage	
Duty cycle	%	100	
Rated frequency	Hz	50	60
Power output at rated voltage	W	0.08	0.085
Speed	rpm	500	600
Running torque at rated voltage	N-cm	0.15	0.14
Power consumption at rated voltage	W	1	1
Detent Torque	N-cm	0.12	

Connection Diagram

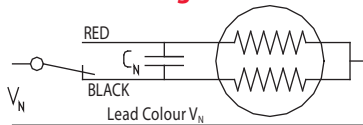

Motor Drawing

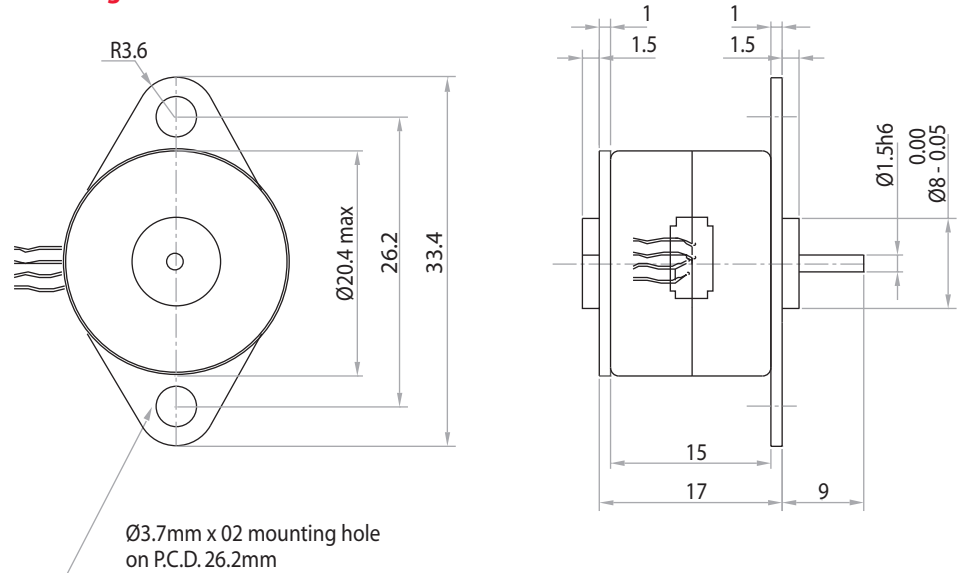

Ordering Data (eg.)

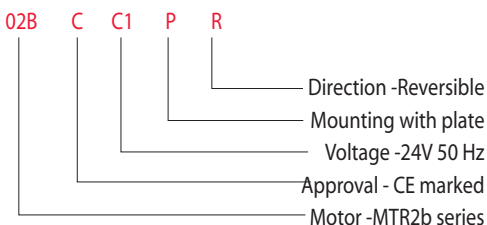

Motor Series MTR3a



Reversible Synchronous Motor - 250 RPM

Application

Recorders, Instrumentation, Diamond machinery, Valve Actuators, Light displays, Textile machinery, Medical equipment, Air conditioning & refrigeration, Dampers, Peristaltic Pumps, Dosing Pumps, Vending machines CCTV Camera positioning, any timing and positioning Application.

Design

MTR3a reversing synchronous motor is of the permanent magnet type with two stator windings, for single phase AC 50/60 Hz. Phase displacement of the excitation current is achieved by connecting a capacitor in series with one of the stator windings. The sense of rotation is determined by the resulting circular rotating field. Electrical reversal of the sense of rotation is effected by means of a single-pole changeover switch. plate.

The 24 pole rotor which has a steel shaft polished to a mirror-finish rotates in sintered bronze bearings.

Motor can be provided with mounting plate/screw clip for fixing.

Standard Data

Motor type		Reversible synchronous
Ambient temperature operation	°C	-15...+55
Ambient temperature storage	°C	-20...+100
Thermal class	°C	105
Electrical Enclosure	IP	40
Connections		Flexible Leads 26 AWG, 200mm length; ends stripped
Sense of rotation		Indicated by lead colour (red-CW & black ACW)
Life expectancy		3 Years in continuous operation
Mounting		any position
HVT		2.0 KV (motor voltage>40V) or 0.6 KV (motor voltage<40V) for 1 min.
Weight	g	65
Rotor stalling		Motor can be stopped when voltage is applied, without being overheated
Rotor shaft		Hardened steel, ground and polished
Bearings		Sintered bronze, self-lubricating
External dimensions		dia. 36 x 21 mm

Technical data

Standard Motor Voltages(V _N)	V	12	24	48	110	220	240*
Operation capacitor(50 Hz)C _N	µF/VAC	10/ 20	3.3/ 50	0.82/ 100	0.15/ 200	With add on units	
Operation capacitor (60Hz) C _N	µF/VAC	10/ 20	3.3/ 50	0.82/ 100	0.15/ 200		
Lead colour (V _N)		Grey	Blue	Brown	White	Yellow	
Tolerance of voltage	%	-10...+15% of rated voltage					
Duty cycle	%	100					
Rated frequency	Hz	50			60		
Power output at rated voltage	W	0.13			0.15		
Speed	rpm	250			300		
Running torque at rated voltage	N-cm	0.5			0.48		
Power consumption at rated voltage	W	1.5			1.5		
Detent Torque	N-cm	0.15					

Connection Diagram

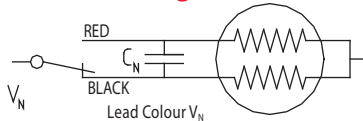

Add on units for 220* & 240* V

220...240 V (V_N motor 110V)

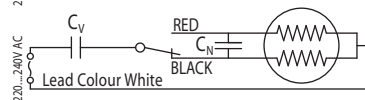
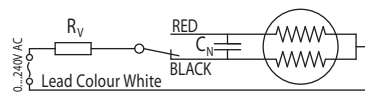

Unit	220V	240V
R _V (1.5W) 50/60Hz	8.2 KΩ	10 KΩ
C _N (200 VAC) 50 Hz	0.18 µF	0.15 µF
C _N (200 VAC) 60 Hz	0.15 µF	0.12 µF

Motor Drawing

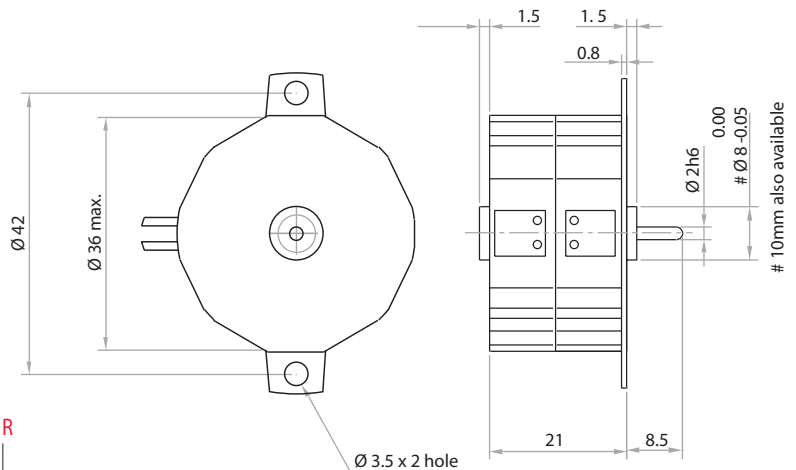

Ordering Data (eg.)

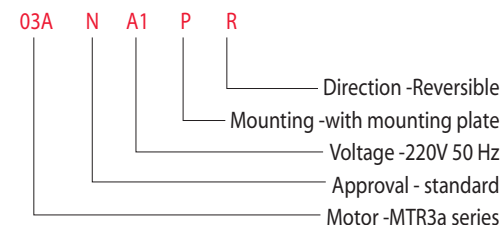

Motor Series **MTR3b**

Reversible Synchronous Motor - 500 RPM



Application

Recorders, Instrumentation, Diamond machinery, Valve Actuators, Light displays, Textile machinery, Medical equipment, Air conditioning & refrigeration, Dampers, Peristaltic Pumps, Dosing Pumps, Vending machines CCTV Camera positioning, any timing and positioning Application.

Design

MTR3b reversing synchronous motor is of the permanent magnet type with two stator windings, for single phase AC 50/60 Hz. Phase displacement of the excitation current is achieved by connecting a capacitor in series with one of the stator windings. The sense of rotation is determined by the resulting circular rotating field. Electrical reversal of the sense of rotation is effected by means of a single-pole changeover switch.

The 12 pole rotor which has a steel shaft polished to a mirror-finish rotates in sintered bronze bearings.

Motor can be provided with Mounting plate/Screw clip for fixing.

Standard Data

Motor type		Reversible synchronous
Ambient temperature operation	°C	-15...+55
Ambient temperature storage	°C	-20...+100
Thermal class	°C	105
Electrical Enclosure	IP	40
Connections		Flexible Leads 26 AWG, 200mm length; ends stripped
Sense of rotation		Indicated by lead colour (red-CW & black ACW)
Life expectancy		3 Years in continuous operation
Mounting		any position
HVT		2.0 KV (motor voltage > 40V) or 0.6 KV (motor voltage < 40V) for 1 min.
Weight	g	65
Rotor stalling		Motor can be stopped when voltage is applied, without being overheated
Rotor shaft		Hardened steel, ground and polished
Bearings		Sintered bronze, self-lubricating
External dimensions		dia. 36 x 21 mm

Technical data

Standard Motor Voltages (V _N)	V	12	24	48	110	220*	240*
Operation capacitor (50 Hz) C _N	µF/VAC	15/ 20	3.9/ 50	1.0/ 100	0.18/ 200	With add on units	
Operation capacitor (60Hz) C _N	µF/VAC	15/ 20	3.9/ 50	1.0/ 100	0.18/ 200		
Lead colour (V _N)		Grey	Blue	Brown	White	Yellow	
Tolerance of voltage	%	-10...+15% of rated voltage					
Duty cycle	%	100					
Rated frequency	Hz	50			60		
Power output at rated voltage	W	0.23			0.25		
Speed	rpm	500			600		
Running torque at rated voltage	N-cm	0.45			0.4		
Power consumption at rated voltage	W	1.5			1.5		
Detent Torque	N-cm	0.13					

Connection Diagram

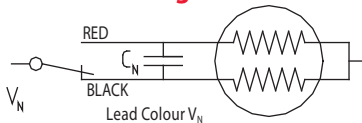

Add on units for 220* & 240* V

220, 240 V (V_N motor 110V)

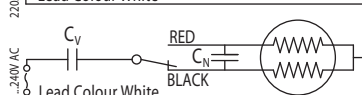
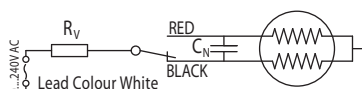

Unit	220V	240V
R _V (1.5W) 50/60Hz	8.2 KΩ	8.2 KΩ
C _N (200 VAC) 50 Hz	0.22 F	0.22 F
C _N (200 VAC) 60 Hz	0.18 F	0.18 F

Motor Drawing

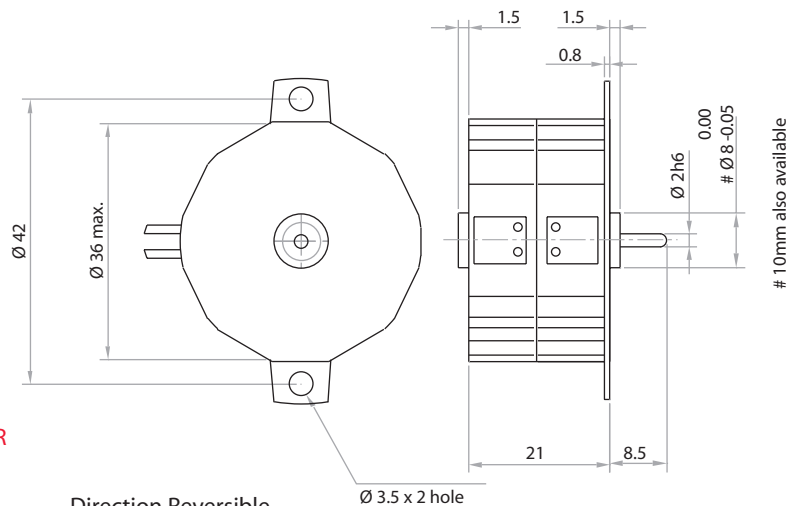

Ordering Data (eg.)

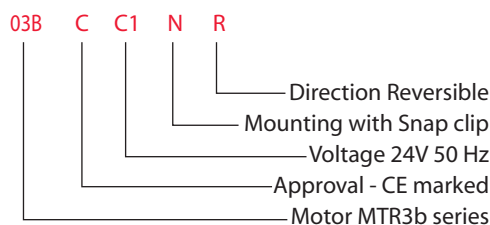

Motor Series **MTR5**

Reversible Synchronous Motor - 500 RPM



Application

Recorders, Instrumentation, Diamond machinery, Valve Actuators, Light displays, Textile machinery, Medical equipment, Air conditioning & refrigeration, Dampers, Peristaltic Pumps, Dosing Pumps, Vending machines CCTV Camera positioning, any timing and positioning Application.

Design

MTR5 reversing synchronous motor is of the permanent magnet type with two stator windings, for single phase AC 50/60 Hz. Phase displacement of the excitation current is achieved by connecting a capacitor in series with one of the stator windings. The sense of rotation is determined by the resulting circular rotating field. Electrical reversal of the sense of rotation is effected by means of a single-pole changeover switch. The 12 pole rotor which has a steel shaft polished to a mirror-finish rotates in sintered bronze bearings.

Motor can be provided with Mounting plate/Screw clip for fixing.

Standard Data

Motor type		Reversible synchronous
Ambient temperature operation	°C	-15...+55
Ambient temperature storage	°C	-20...+100
Thermal class	°C	105
Electrical Enclosure	IP	40
Connections		Flexible Leads 22 AWG, 200mm length; ends stripped
Sense of rotation		Indicated by lead colour (red-CW & black ACW)
Life expectancy		3 Years in continuous operation
Mounting		any position
HVT		2.0 KV (motor voltage>40V) or 0.6 KV (motor voltage<40V) for 1 min.
Weight	g	140
Rotor stalling		Motor can be stopped when voltage is applied, without being overheated
Rotor shaft		Hardened steel, ground and polished
Bearings		Sintered bronze, self-lubricating
External dimensions		dia. 48 x 25 mm

Technical data

Rated voltage V_N	V	12	24	48	110	220	240
Operation capacitor (50/60 Hz) C_N	$\mu\text{F/VAC}$	22/20	6.8/40	1.5/100	0.27/200	0.068/400	0.068/400
Operation capacitor (50/60 Hz) C_N	$\mu\text{F/VAC}$	22/20	6.8/40	1.5/100	0.27/200	0.068/400	0.068/400
Lead colour (V_N)		Grey	Blue	Brown	White	Yellow	Yellow
Tolerance of voltage	%	-10... +15% of rated voltage					
Duty cycle	%	100					
Rated frequency	Hz				50	60	
Power output at rated voltage	W				0.41	0.42	
Speed	rpm				500	600	
Running torque at rated voltage	N-cm				0.8	0.75	
Power consumption at rated voltage	W				2.1	2.2	
Detent torque	N-cm	0.3					

Connection Diagram

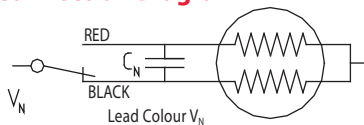

Motor Drawing

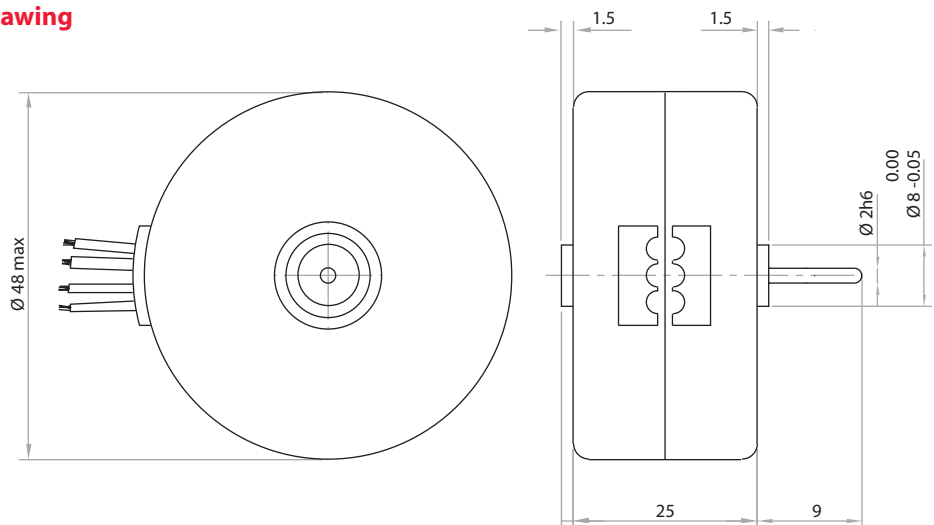

Ordering Data (eg.)

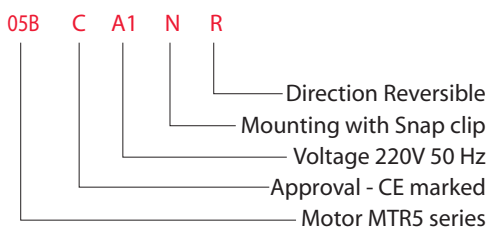

Motor Series **MTR4a**

Reversible Synchronous Motor - 250 RPM

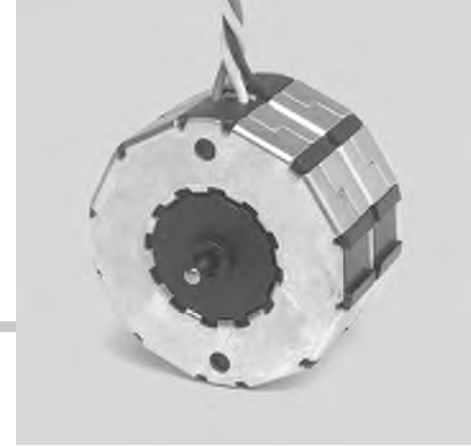

Application

Recorders, Instrumentation, Diamond machinery, Valve Actuators, Light displays, Textile machinery, Medical equipment, Air conditioning & refrigeration, Dampers, Peristaltic Pumps, Dosing Pumps, Vending machines CCTV Camera positioning, any timing and positioning Application.

Design

MTR3b reversing synchronous motor is of the permanent magnet type with two stator windings, for single phase AC 50/60 Hz. Phase displacement of the excitation current is achieved by connecting a capacitor in series with one of the stator windings. The sense of rotation is determined by the resulting circular rotating field. Electrical reversal of the sense of rotation is effected by means of a single-pole changeover switch.

The 12 pole rotor which has a steel shaft polished to a mirror-finish rotates in sintered bronze bearings.

Motor can be provided with Mounting plate/Screw clip for fixing.

Standard Data

Motor type		Reversible synchronous
Ambient temperature operation	°C	-15...+55
Ambient temperature storage	°C	-20...+100
Thermal class	°C	105
Electrical Enclosure	IP	40
Connections		Flexible Leads 22 AWG, 200mm length; ends stripped
Sense of rotation		Indicated by lead colour (red-CW & black ACW)
Life expectancy		3 Years in continuous operation
Mounting		any position
HVT		2.0 KV (motor voltage>40V) or 0.6 KV (motor voltage<40V) for 1 min.
Weight	g	200
Rotor stalling		Motor can be stopped when voltage is applied, without being overheated
Rotor shaft		Hardened steel, ground and polished
Bearings		Sintered bronze, self-lubricating
External dimensions		dia. 52 x 28.5 mm

Technical data

Standard Motor Voltages(V _N)	V	24	48	110	220	240
Operation capacitor(50 Hz)C _N	µF/VAC	10/50	2.2/100	0.39/250	0.1/400	0.1/400
Operation capacitor (60Hz) C _N	µF/VAC	8.2/50	1.8/100	0.33/250	0.082/400	0.082/400
Lead colour (V _N)		Blue	Brown	White	Yellow	Yellow
Tolerance of voltage	%	-10...+15% of rated voltage				
Duty cycle	%	100				
Rated frequency	Hz	50		60		
Power output at rated voltage	W	0.6		0.63		
Speed	rpm	250		300		
Running torque at rated voltage	N-cm	2.4		2.1		
Power consumption at rated voltage	W	3.1		3.2		
Detent Torque	N-cm	0.6				

Connection Diagram

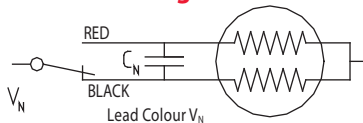

Motor Drawing

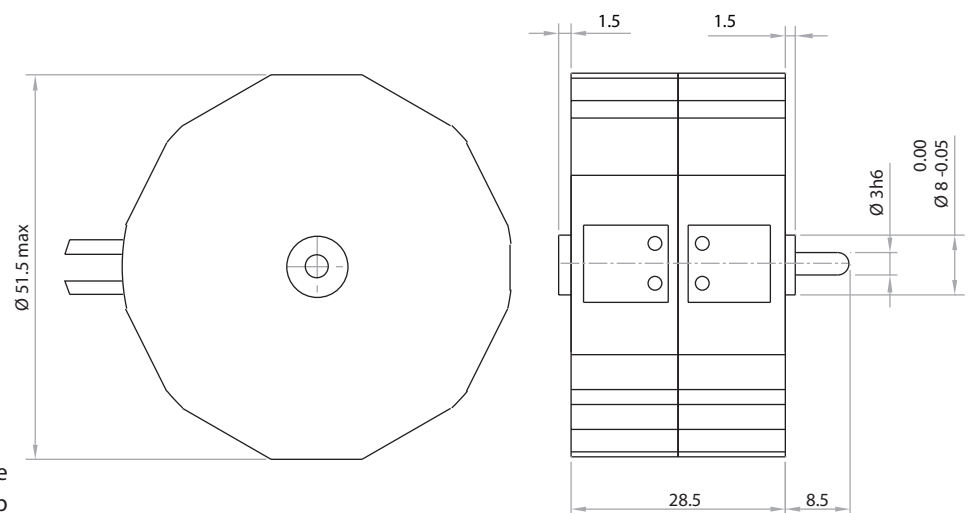

Ordering Data (eg.)

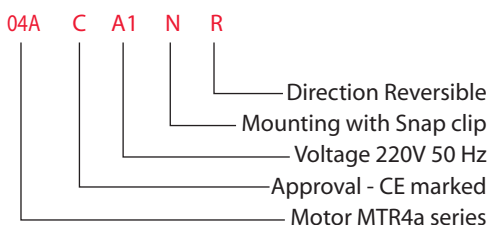

Motor Series **MTR4b**

Reversible Synchronous Motor - 500 RPM

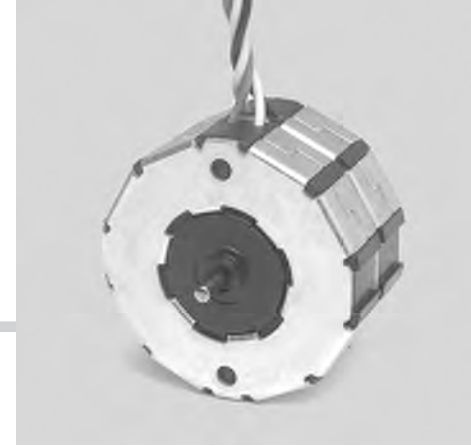

Application

Valve Actuators, Light displays, Textile machinery, Medical equipment, Air conditioning & refrigeration, Dampers peristaltic Pumps, Dosing pumps, Vending machines, CCTV Camera positioning, any positioning Application.

Design

MTR4b reversing synchronous motor is of the permanent magnet type with two stator windings, for single phase AC 50/60 Hz. Phase displacement of the excitation current is achieved by connecting a capacitor in series with one of the stator windings. The sense of rotation is determined by the resulting circular rotating field. Electrical reversal of the sense of rotation is effected by means of a single-pole changeover switch.

The 12 pole rotor which has a steel shaft polished to a mirror-finish rotates in sintered bronze bearings.

Motor can be provided with Mounting plate/ Screw clip for fixing.

Standard Data

Motor type		Reversible synchronous
Ambient temperature operation	°C	-15...+55
Ambient temperature storage	°C	-20...+100
Thermal class	°C	105
Electrical Enclosure	IP	40
Connections		Flexible Leads 22 AWG, 200mm length; ends stripped
Sense of rotation		Indicated by lead colour (red-CW & black ACW)
Life expectancy		3 Years in continuous operation
Mounting		any position
HVT		2.0 KV (motor voltage>40V) or 0.6 KV (motor voltage<40V) for 1 min.
Weight	g	200
Rotor stalling		Motor can be stopped when voltage is applied, without being overheated
Rotor shaft		Hardened steel, ground and polished
Bearings		Sintered bronze, self-lubricating
External dimensions		dia. 52 x 28.5 mm

Technical data

Standard Motor Voltages(V _N)	V	24	48	110	220	240
Operation capacitor(50 Hz)C _N	µF/VAC	10/50	2.7/100	0.47/250	0.12/400	0.1/400
Operation capacitor (60Hz) C _N	µF/VAC	8.2/50	2.2/100	0.39/250	0.1/400	0.082/400
Lead colour (V _N)		Blue	Brown	White	Yellow	Yellow
Tolerance of voltage	%	-10...+15% of rated voltage				
Duty cycle	%	100				
Rated frequency	Hz			50	60	
Power output at rated voltage	W			0.83	0.87	
Speed	rpm			500	600	
Running torque at rated voltage	N-cm			1.6	1.5	
Power consumption at rated voltage	W			3.6	3.7	
Detent Torque	N-cm			0.75		

Connection Diagram

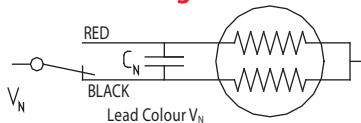

Motor Drawing

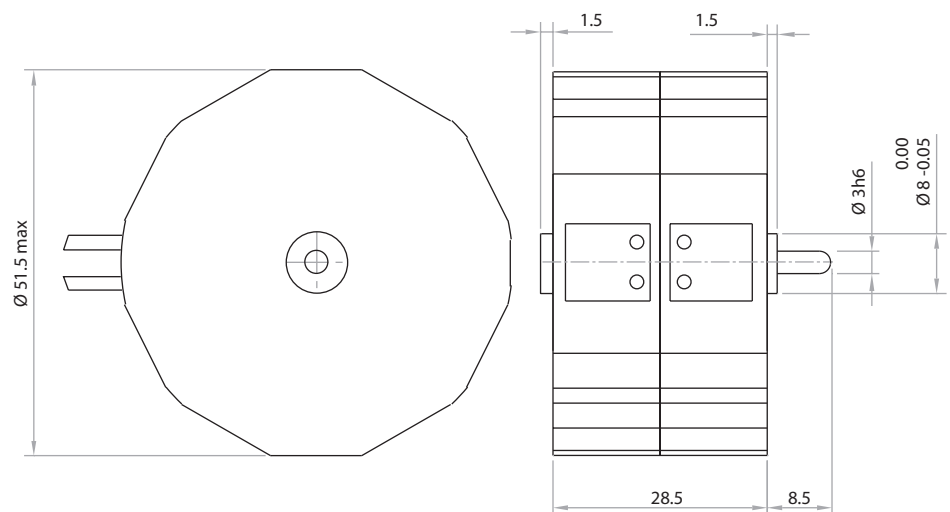

Ordering Data (eg.)

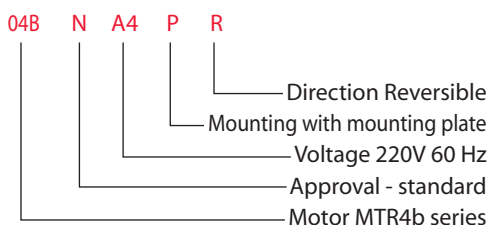

Motor Series **MTRD4b**

Reversible Synchronous Motor - 500 RPM

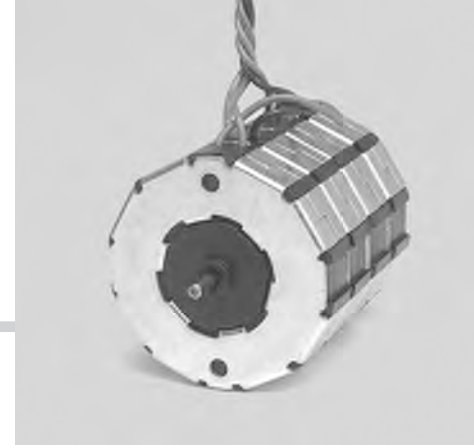

Application

Recorders, Instrumentation, Diamond machinery, Valve Actuators, Light displays, Textile machinery, Medical equipment, Air conditioning & refrigeration, Dampers, Peristaltic Pumps, Dosing Pumps, Vending machines CCTV Camera positioning, any timing and positioning Application.

Design

MTRD4b reversing synchronous motor is of the permanent magnet type with two stator windings, for single phase AC 50/60 Hz. Phase displacement of the excitation current is achieved by connecting a capacitor in series with one of the stator windings. The sense of rotation is determined by the resulting circular rotating field. Electrical reversal of the sense of rotation is effected by means of a single-pole changeover switch.

The 12 pole rotor which has a steel shaft polished to a mirror-finish rotates in sintered bronze bearings.

Motor can be provided with Mounting plate/ Screw clip for fixing.

Standard Data

Motor type		Reversible synchronous
Ambient temperature operation	°C	-15...+55
Ambient temperature storage	°C	-20...+100
Thermal class	°C	105
Electrical Enclosure	IP	40
Connections		Flexible Leads 22 AWG, 200mm length; ends stripped
Sense of rotation		Indicated by lead colour (red-CW & black ACW)
Life expectancy		3 Years in continuous operation
Mounting		any position
HVT		2.0 KV (motor voltage>40V) or 0.6 KV (motor voltage<40V) for 1 min.
Weight	g	400
Rotor stalling		Motor can be stopped when voltage is applied, without being overheated
Rotor shaft		Hardened steel, ground and polished
Bearings		Sintered bronze, self-lubricating
External dimensions		dia. 52 x 57 mm

Technical data

Standard Motor voltage V_N	V	24	48	110	220	240
Operation capacitor (50 Hz) C_N	$\mu\text{F/VAC}$	18/50	4.7/100	0.82/250	0.22/400	0.22/400
Operation capacitor (60 Hz) C_N	$\mu\text{F/VAC}$	15/50	3.9/100	0.68/250	0.18/400	0.18/400
Lead colour (V_N)		Blue	Brown	White	Yellow	Yellow
Tolerance of voltage	%	-10... +15% of rated voltage				
Duty cycle	%	100				
Rated frequency	Hz	50				60
Power output at rated voltage	W	1.7				1.7
Speed	rpm	500				600
Running torque at rated voltage	N-cm	3				2.8
Power consumption at rated voltage	W	7				7.5
Detent torque	N-cm	1.5				

Connection Diagram

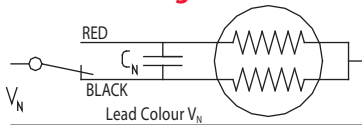

Motor Drawing

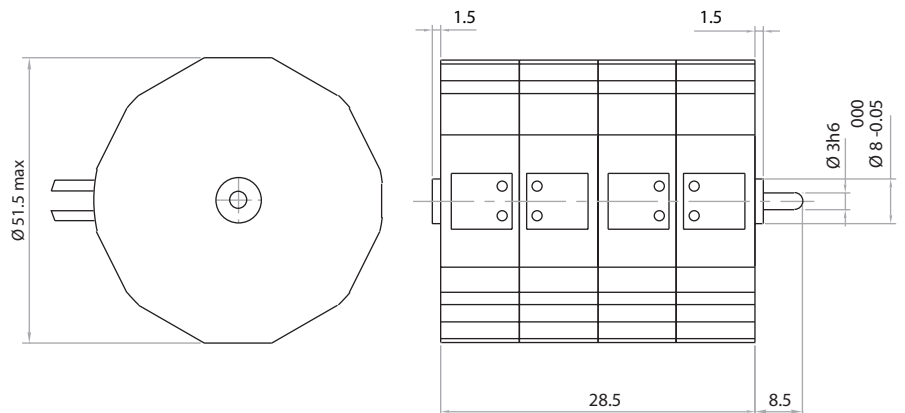

Ordering Data (eg.)

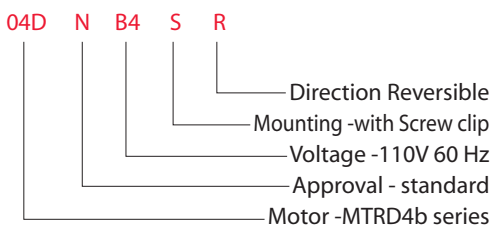

Motor Series MTR7a



Reversible Synchronous Motor - 250 RPM

Application

Reversible power drive for actuators, pumps, label printing machines, medical and optical equipment, office machines, automatic vending machines, machine automation

Design

The MTR7a reversing synchronous motor with permanent magnet rotor is electrically reversible and due to its unique stator design it is moderately priced. The rotating field is produced with a phase-shift capacitor and double-stator with coils thus ensuring extremely quiet running. Long life is guaranteed by the robust sintered bronze bearings. The MTR7a is operated with single-phase AC current.

The same motor version can be used at 50Hz and 60Hz.

Standard Data

Motor type		Reversible synchronous
Ambient temperature operation	°C	-15...+55
Ambient temperature storage	°C	-20...+100
Thermal class	°C	105
Electrical Enclosure	IP	40
Connections		Flexible Leads 22 AWG, 200mm length; ends stripped
Sense of rotation		Indicated by lead colour (red-CW & black ACW)
Life expectancy		3 Years in continuous operation
Mounting		any position
HVT		2.0 KV (motor voltage > 40V) or 0.6 KV (motor voltage < 40V) for 1 min.
Weight	g	300
Rotor stalling		Motor can be stopped when voltage is applied, without being overheated
Rotor shaft		Hardened steel, ground and polished
Bearings		Sintered bronze, self-lubricating
External dimensions		dia. 59 x 35 mm

Technical data

Standard Motor voltage V_N	V	12	24	48	110	220	240
Operation capacitor (50/60 Hz) C_N	$\mu\text{F/VAC}$	56/40	15/50	3.9/100	0.68/250	0.18/400	0.18/400
Operation capacitor (50/60 Hz) C_N	$\mu\text{F/VAC}$	39/40	10/50	2.7/100	0.47/250	0.12/400	0.12/400
Lead colour (V_N)		Grey	Blue	Brown	White	Yellow	Yellow
Tolerance of voltage	%	-10... +15% of rated voltage					
Duty cycle	%	100					
Rated frequency	Hz					50	60
Power output at rated voltage	W					2.2	2.1
Speed	rpm					250	300
Running torque at rated voltage	N-cm					6	4.5
Power consumption at rated voltage	W					5.8	5
Detent torque	N-cm	1.3					

Connection Diagram

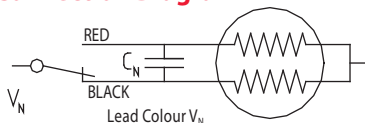

Motor Drawing

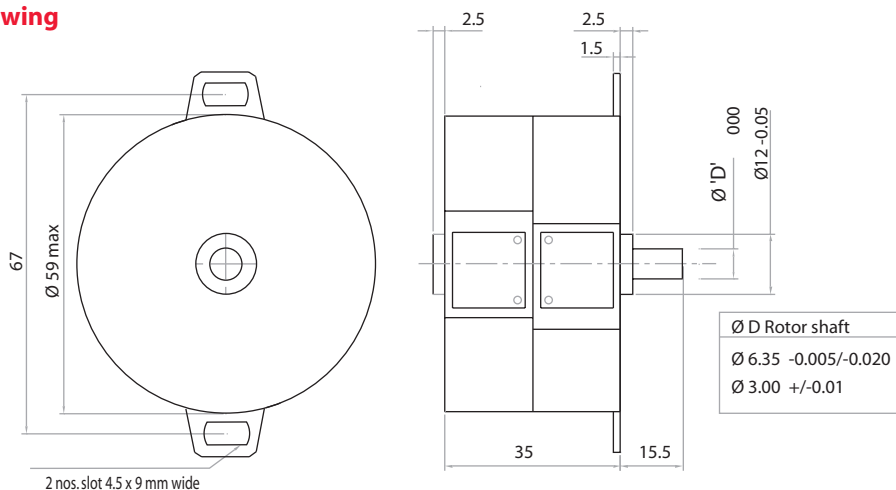

Ordering Data (eg.)

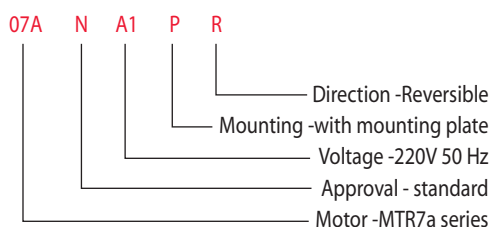

Motor Series MTR8c

Reversible Synchronous Motor - 375 RPM



Application

Reversible power drive for actuators, pumps, label printing machines, medical and optical equipment, office machines, automatic vending machines, machine automation.

Design

The MTR8c reversing synchronous motor with permanent magnet rotor is electrically reversible and due to its unique stator design it is moderately priced. The rotating field is produced with a phase-shift capacitor and double-stator with coils thus ensuring extremely quiet running. Long life is guaranteed by the robust design (sintered bronze bearings; self-centering type). The MTR8c is operated with single-phase AC current.

The same motor version can be used at 50Hz and 60Hz

Various windings of motor are available that are tailored to specific requirements. Only some types are listed.

Standard Data

Motor type		Reversible synchronous
Ambient temperature operation	°C	-15...+55
Ambient temperature storage	°C	-20...+100
Thermal class	°C	130
Electrical Enclosure	IP	40
Connections		Flexible Leads 22 AWG, 200mm length; ends stripped
Sense of rotation		Indicated by lead colour (red-CW & black ACW)
Life expectancy		3 Years in continuous operation
Mounting		any position
HVT		2.0 KV (motor voltage > 40V) or 0.6 KV (motor voltage < 40V) for 1 min.
Weight	g	450
Rotor stalling		Motor can be stopped when voltage is applied, without being overheated
Rotor shaft		Hardened steel, ground and polished
Bearings		Sintered bronze, self-lubricating
External dimensions		dia. 66.4 x 40.4 mm

Technical data

Rated voltage V_N	V	24	110	220	240	
Operation capacitor (50 Hz) C_N	$\mu\text{F}/\text{VAC}$	27/50	1.33/250	0.33/500	0.27/500	
Operation capacitor (60 Hz) C_N	$\mu\text{F}/\text{VAC}$	27/50	1.33/250	0.33/500	0.27500	
Lead colour (V_N)		Blue	White	Yellow	Yellow	
Tolerance of voltage	%	-10... +15% of rated voltage				
Duty Cycle	%	100				
Rated frequency	Hz	50			60	
Speed	rpm	375			450	
Power consumption at rated voltage	W	9.5			9.7	
Running torque at rated voltage	N-cm	10.50			8.5	
Intermittent Duty cycle	%	90 (90min)	10 min	90 (90min)	10 min	
Power output at V_N	W	4.6	7.3	4.9	8	
Power consumption at V_N	W	11.5	18	12.5	20	
Running torque at rated voltage	N-cm	12	18.5	10.5	17	
Detent torque	N-cm	1.8				

Connection Diagram

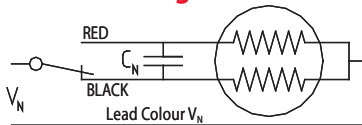

Technical Data (Strong magnet)

Duty cycle	%	70	20 (10min)	10 (5min)	70	20 (10min)	10 (5min)
Power consumption at V_N	W	14.5	25	32	15	25	32
Running torque at rated voltage	N-cm	17	27	34	14.5	21	30
Detent torque	N-cm	7.5					

Motor Drawing

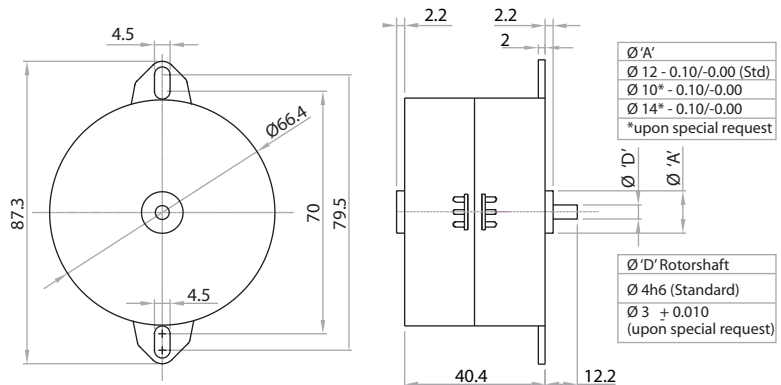

Ordering Data (eg.)

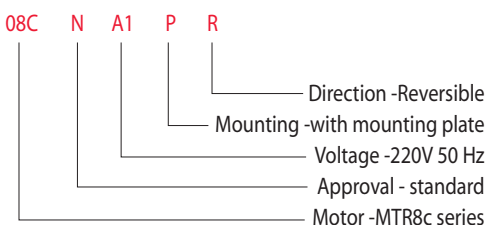

Motor Series **MTR9a**

Reversible Synchronous Motor - 1000 RPM



Application

Reversible power drive for special purpose m/cs, actuators, pumps, label printing machines, medical and optical equipment, vending machines etc.

Design

The MTR9a reversing synchronous motor with permanent magnet rotor. The rotating field is produced with a phase-shift capacitor and double-stator with coils thus ensuring extremely quiet running and smooth operation. Long life is ensured by the ball bearings. Compared to normal permanent magnet synchronous motor that operates on tin can principle, these motors are more efficient. At same time the temperature rise is significantly higher in this motor. MTR9a is operated with single-phase AC current.

The same motor version can be used at 50Hz and 60Hz.

Standard Data

Motor type		Reversible synchronous
Ambient temperature operation	°C	-15...+55
Ambient temperature storage	°C	-20...+100
Thermal class	°C	130
Electrical Enclosure	IP	40
Connections		Flexible Leads 26 AWG, 200mm length; ends stripped
Sense of rotation		Indicated by lead colour (red-CW & black ACW)
Mounting		any position
HVT		2.0 KV (motor voltage > 40V) or 0.6 KV (motor voltage < 40V) for 1 min.
Weight	g	500
Temperature rise over ambient	°C	80max
Rotor shaft		Steel, ground and polished
Bearings		Ball bearings
External dimensions		sqr. 64 x 55 mm

Technical data

Rated voltage V_N	V	24	110	220
Operation capacitor (50 Hz) C_N	$\mu\text{F}/\text{VAC}$	42/50	2/250	0.5/500
Operation capacitor (60 Hz) C_N	$\mu\text{F}/\text{VAC}$	42/50	2/250	0.5/500
Lead colour (V_N)		Blue	White	Yellow
Tolerance of voltage	%	-10... +15% of rated voltage		
Duty cycle	%	Intermittent		
Rated frequency	Hz	50	60	
Power output at rated voltage	W	8.8	9.9	
Speed	rpm	1000	1200	
Running torque at rated voltage	N-cm	8.4	7.8	
Power consumption at rated voltage	W	17.1	19.3	
Detent torque	N-cm	2		

Connection Diagram

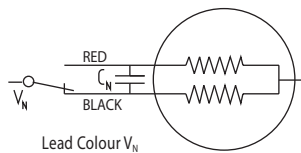

Motor Drawing

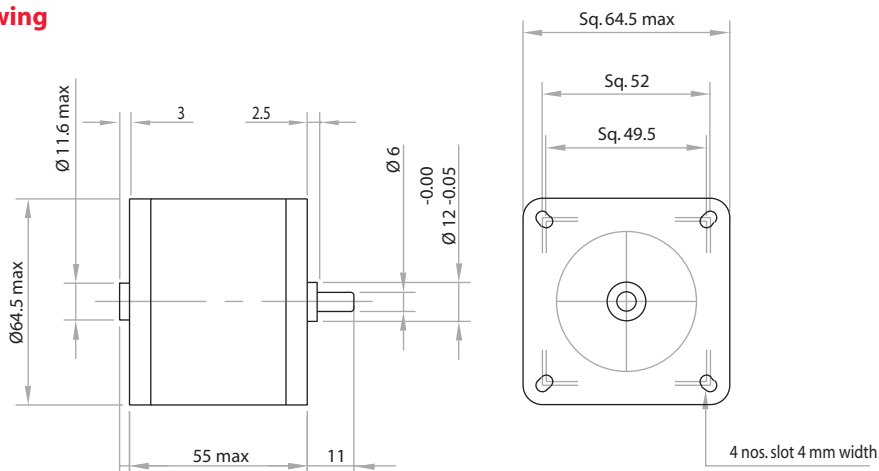

Ordering Data (eg.)

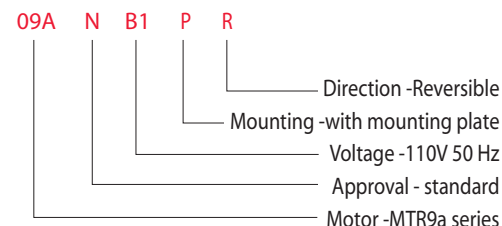

Motor Series **MTR9b**

Reversible Synchronous Motor - 1000 RPM

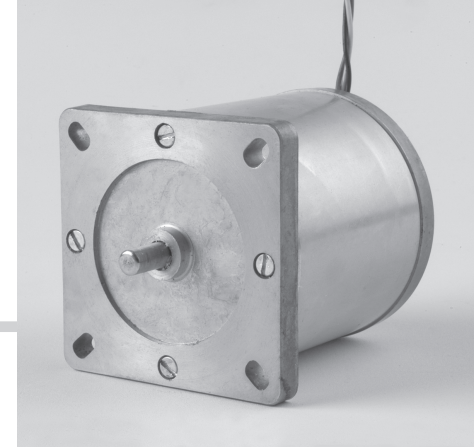

Application

Reversible power drive for special purpose m/cs, actuators, pumps, label printing machines, medical and optical equipment, vending machines etc.

Design

The MTR9b reversing synchronous motor with permanent magnet rotor. The rotating field is produced with a phase-shift capacitor and double-stator with coils thus ensuring extremely quiet running and smooth operation. Long life is ensured by the ball bearings. Compared to normal permanent magnet synchronous motor that operates on tin can principle, these motors are more efficient. At same time the temperature rise is significantly higher in this motor. MTR9b is operated with single-phase AC current.

The same motor version can be used at 50Hz and 60Hz.

Standard Data

Motor type		Reversible synchronous
Ambient temperature operation	°C	-15...+55
Ambient temperature storage	°C	-20...+100
Thermal class	°C	130
Electrical Enclosure	IP	40
Connections		Flexible Leads 26 AWG, 200mm length; ends stripped
Sense of rotation		Indicated by lead colour (red-CW & black ACW)
Mounting		any position
HVT		2.0 KV (motor voltage > 40V) or 0.6 KV (motor voltage < 40V) for 1 min.
Weight	g	750
Temperature rise over ambient	°C	80max
Rotor shaft		Steel, ground and polished
Bearings		Ball bearings
External dimensions		sqr. 64 x 69 mm

Technical data

Rated voltage V_N	V	24	110	220	
Operation capacitor (50 Hz) C_N	$\mu\text{F/VAC}$	48/50	2.5/250	0.6/400	
Operation capacitor (60 Hz) C_N	$\mu\text{F/VAC}$	48/50	2.5/250	0.6/400	
Lead colour (V_N)		Blue	White	Yellow	
Tolerance of voltage	%	-10... +15% of rated voltage			
Duty cycle	%	Intermittent			
Rated frequency	Hz	50		60	
Power output at rated voltage	W	10.1		11.3	
Speed	rpm	1000		1200	
Running torque at rated voltage	N-cm	9.6		9	
Power consumption at rated voltage	W	20.7		23.7	
Detent torque	N-cm	3.4			

Connection Diagram

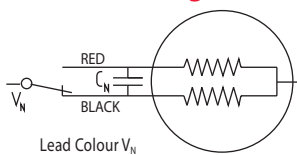

Ordering Data (eg.)

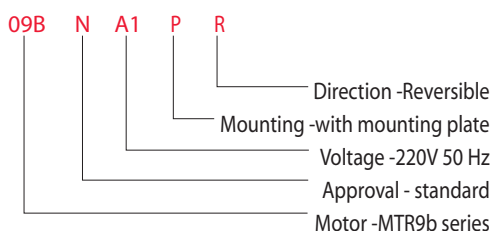

Motor Drawing

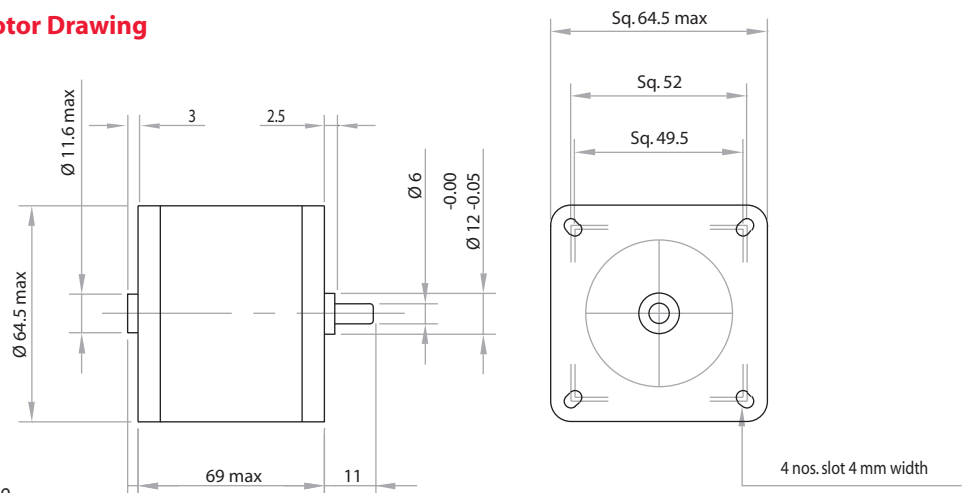

Motor Series MTR9d



Reversible Synchronous Motor - 1000 RPM

Application

Reversible power drive for special purpose m/cs, actuators, pumps, label printing machines, medical and optical equipment, vending machines etc.

Design

The MTR9b reversing synchronous motor with permanent magnet rotor. The rotating field is produced with a phase-shift capacitor and double-stator with coils thus ensuring extremely quiet running and smooth operation. Long life is ensured by the ball bearings. Compared to normal permanent magnet synchronous motor that operates on tin can principle, these motors are more efficient. At same time the temperature rise is significantly higher in this motor. MTR9b is operated with single-phase AC current.

The same motor version can be used at 50Hz and 60Hz.

Standard Data

Motor type		Reversible synchronous
Ambient temperature operation	°C	-15...+55
Ambient temperature storage	°C	-20...+100
Thermal class	°C	130
Electrical Enclosure	IP	40
Connections		Flexible Leads 26 AWG, 200mm length; ends stripped
Sense of rotation		Indicated by lead colour (red-CW & black ACW)
Mounting		any position
HVT		2.0 KV (motor voltage>40V) or 0.6 KV (motor voltage<40V) for 1 min.
Weight	g	1250
Temperature rise over ambient	°C	80max
Rotor shaft		Steel, ground and polished
Bearings		Ball bearings
External dimensions		sqr. 64 x 111 mm

Technical data

Rated voltage V_N	V	24	110	220	
Operation capacitor (50 Hz) C_N	μ F/VAC	70/50	3.3/250	0.82/500	
Operation capacitor (60 Hz) C_N	μ F/VAC	70/50	3.3/250	0.82/500	
Lead colour (V_N)		Blue	White	Yellow	
Tolerance of voltage	%	-10... +15% of rated voltage			
Duty cycle	%	Intermittent			
Rated frequency	Hz	50		60	
Power output at rated voltage	W	18.9		19.2	
Speed	rpm	1000		1200	
Running torque at rated voltage	N-cm	18		15	
Power consumption at rated voltage	W	30.1		33.7	
Detent torque	N-cm	6			

Connection Diagram

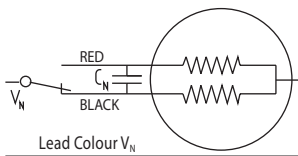

Motor Drawing

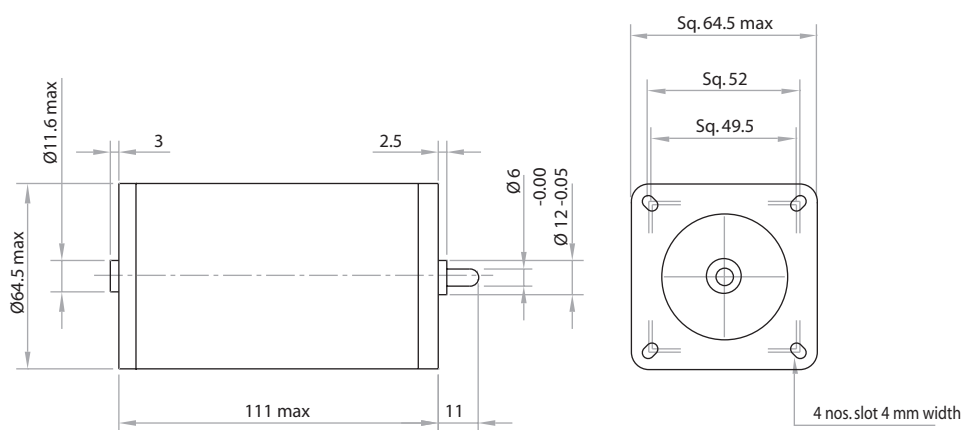

Ordering Data (eg.)

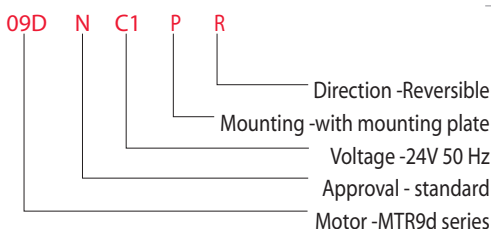

Motor Series **MTS2b**

Stepper Motor 15°



Standard Data

Motor type		Permanent Magnet (PM) stepper motor
Electrical Enclosure	IP	40
Connections		Flexible Leads 28 AWG, 200mm length; ends stripped
Life expectancy		3 years in continuous operation
Weight		30
Mounting		Any position by ears

Technical Data

Steps per revolution		24		
Degree/step		15		
Winding type		bipolar		
Standard voltages	V	6	12	24
Resistance per winding	Ω	27	125	500
Winding Type		unipolar		
Standard Voltage	V	6	12	24
Resistance per winding	Ω	35	150	600
Winding temperature	$^{\circ}\text{C}$	105 max.		
Holding torque	N-cm	0.4 (MTSB2b)	0.3 (MTSU2b)	
Axial Force	N	1		
Lateral Force	N	0.8		
Rotor inertia	g-cm^2	0.3		

Drawing

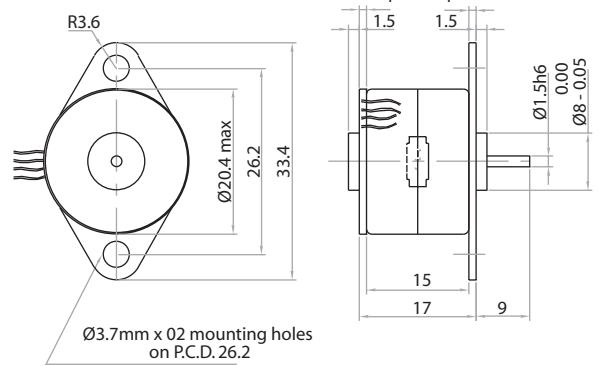

Ordering Data (eg.)

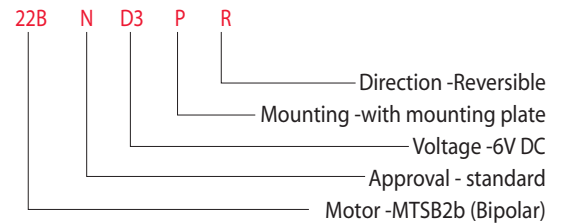

Torque Graphs

Start range (pull - in) with constant voltage power stage

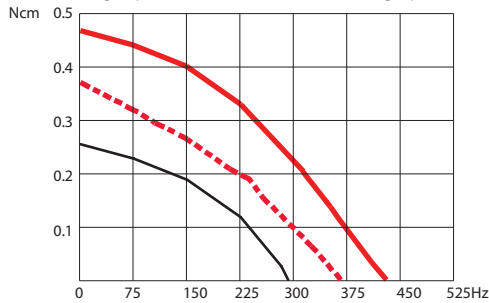

2-Phase stepper Motor MTSB2b

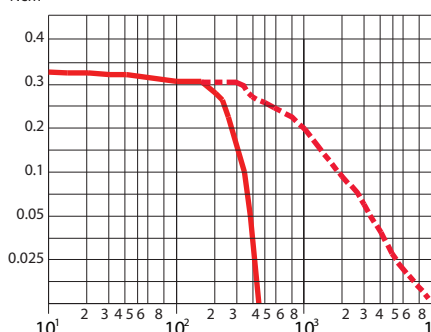

Slew range (pull-out) and start range (pull-in) with constant current power stage (chopper Drive)

Start range (pull - in) with constant voltage power stage

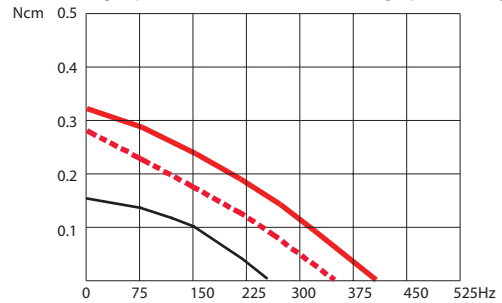

2-Phase stepper Motor MTSU2b

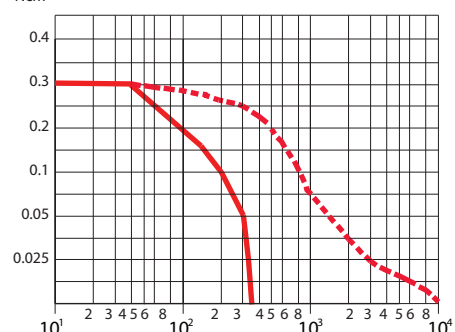

Slew range (pull-out) and start range (pull-in) with constant current power stage (chopper Drive)

Motor Series MTS3a



Stepper Motor 7.5°

Standard Data

Motor type		Permanent Magnet (PM) stepper motor
Electrical Enclosure	IP	40
Connections		Flexible Leads 26 AWG, 200mm length; ends stripped
Life expectancy		3 years in continuous operation
Weight	g	65
Mounting		Any position by ears or screw clip

Technical Data

Steps per revolution		48			
Degree/step		7.5			
Winding Type		bipolar			
Standard Voltage	V	3	6	12	24
Resistance per winding	Ω	11.5	18.5	100	460
Winding Type		unipolar			
Standard Voltage	V	3	6	12	24
Resistance per winding	Ω	12	28.5	120	500
Winding temperature	$^{\circ}\text{C}$	105 max.			
Holding torque	N-cm	1.3 (MTSB3a)	1 (MTSU3a)		
Axial Force	N	1			
Lateral Force	N	3			
Rotor inertia	g-cm ²	2.9			

Drawing

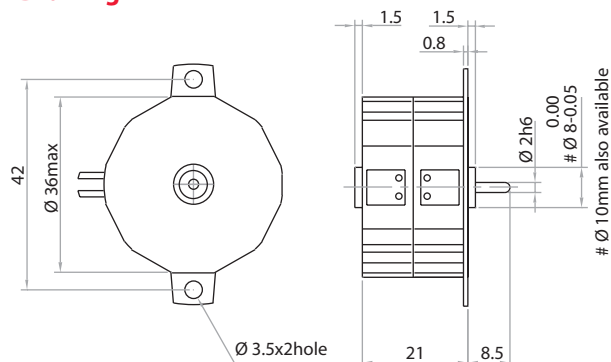

Ordering Data (eg.)

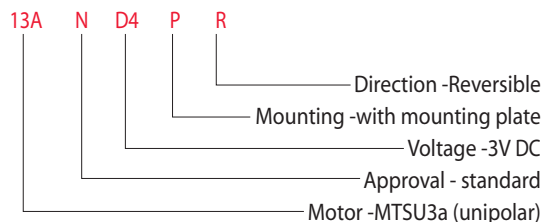

Torque Graphs

Start range (pull - in) with constant voltage power stage

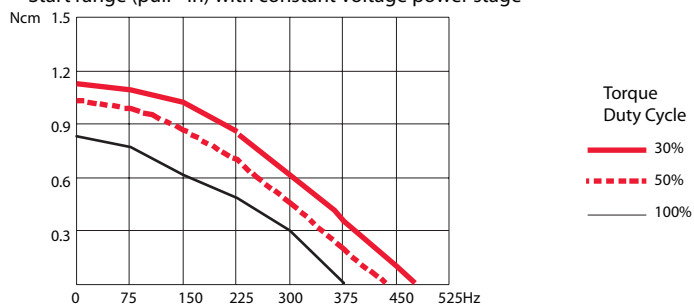

Start range (pull - in) with constant voltage power stage

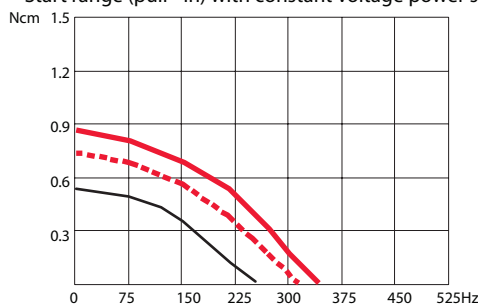

2-Phase stepper Motor MTSB3a

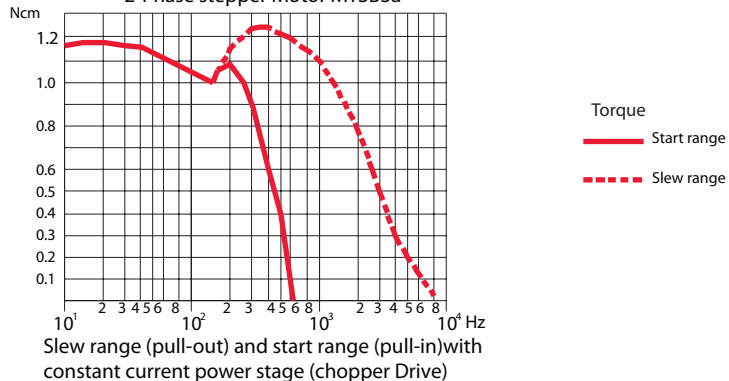

4-Phase stepper Motor MTSU3a



Motor Series **MTS3b**

Stepper Motor 15°



Standard Data

Motor type		Permanent Magnet (PM) stepper motor
Electrical Enclosure	IP	40
Connections		Flexible Leads 26 AWG, 200mm length; ends stripped
Life expectancy		3 years in continuous operation
Weight	g	65
Mounting		Any position by ears or screw clip

Technical Data

Steps per revolution		48			
Degree/step		1.5			
Winding Type		bipolar			
Standard Voltage	V	3	6	12	24
Resistance per winding	Ω	11.5	18.5	100	460
Winding Type		unipolar			
Standard Voltage	V	3	6	12	24
Resistance per winding	Ω	12	28.5	120	500
Winding temperature	$^{\circ}\text{C}$	105 max.			
Holding torque	N-cm	1.2	(MTSB3b)	1	(MTSU3b)
Axial Force	N	1			
Lateral Force	N	3			
Rotor inertia	g-cm ²	2.9			

Drawing

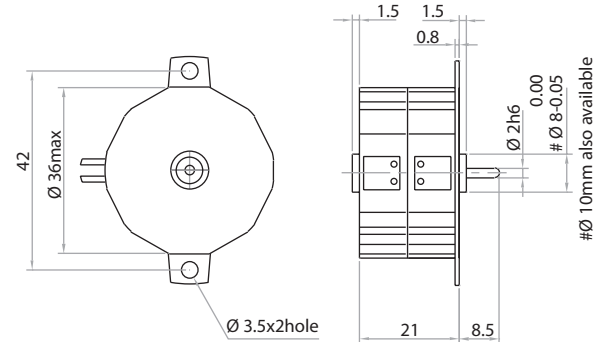

Ordering Data (eg.)

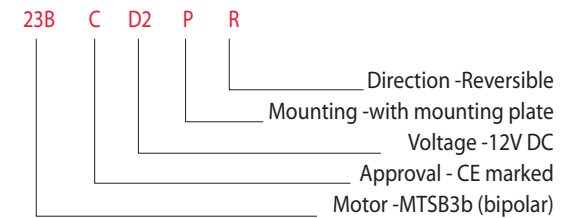

Torque Graphs

Start range (pull-in) with constant voltage power stage

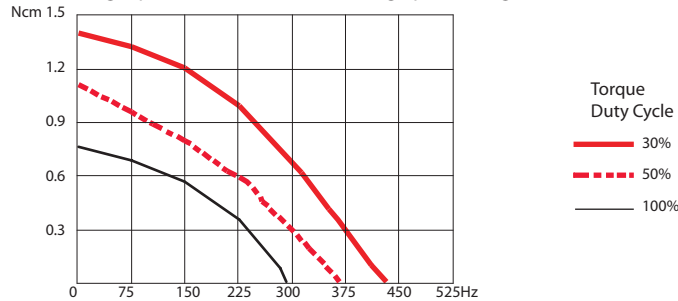

2-Phase stepper Motor MTSB3b

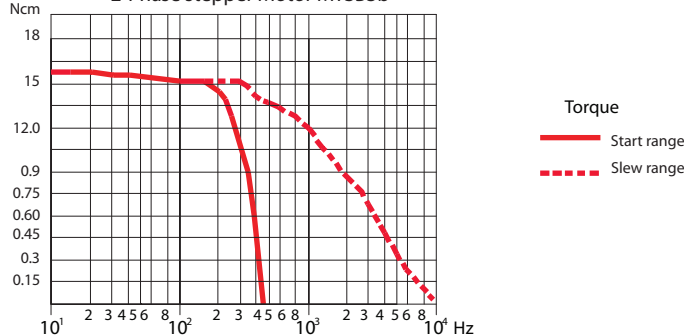

Slew range (pull-out) and start range (pull-in) with constant current power stage (chopper Drive)

Start range (pull-in) with constant voltage power stage

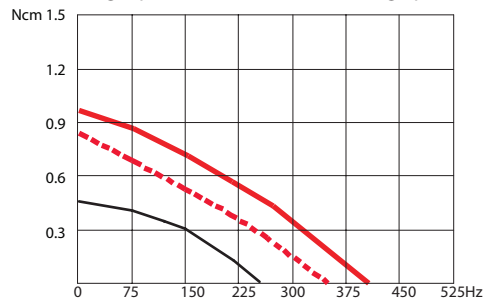

4-Phase stepper Motor MTSU3b

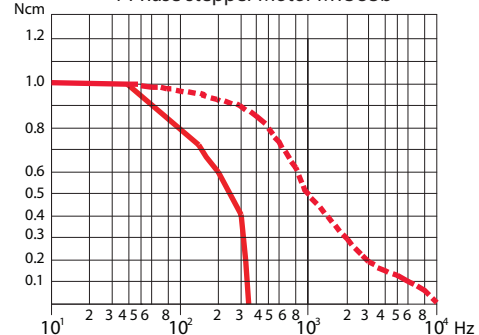

Slew range (pull-out) and start range (pull-in) with constant current power stage (chopper Drive)

Motor Series **MTS5**

Stepper Motor 15°



Standard Data

Motor type		Permanent Magnet (PM) stepper motor
Electrical Enclosure	IP	40
Connections		Flexible Leads 26 AWG, 200mm length; ends stripped
Life expectancy		3 years in continuous operation
Weight	g	140
Mounting		Any position by ears or screw clip

Technical Data

Steps per revolution		48		
Degree/step		1.5		
Winding Type		bipolar		
Standard Voltage	V	6	12	24
Resistance per winding	Ω	15	78	300
Winding Type		unipolar		
Standard Voltage	V	6	12	24
Resistance per winding	Ω	20	78	300
Winding temperature	$^{\circ}\text{C}$	105 max.		
Holding torque	N-cm	2.3	(MTSB5)	2 (MTSU5)
Axial Force	N	2		
Lateral Force	N	4		
Rotor inertia	g-cm ²	6		

Drawing

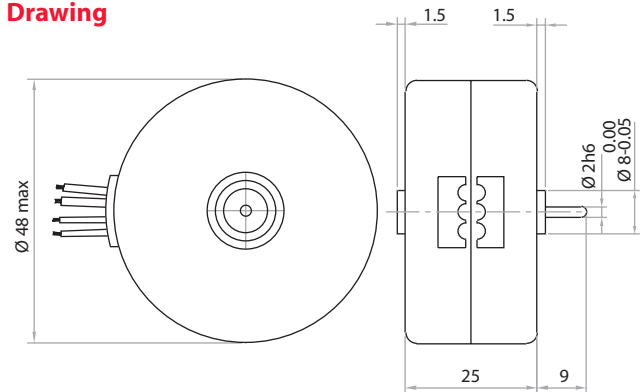

Ordering Data (eg.)

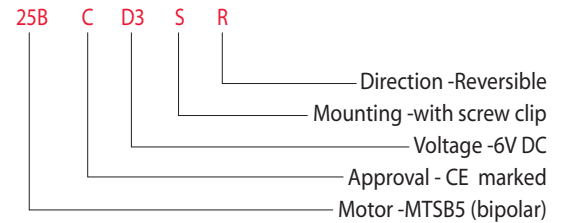

Torque Graphs

Start range (pull - in) with constant voltage power stage

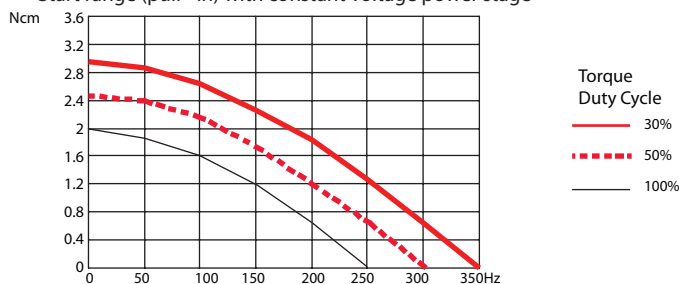

Start range (pull - in) with constant voltage power stage

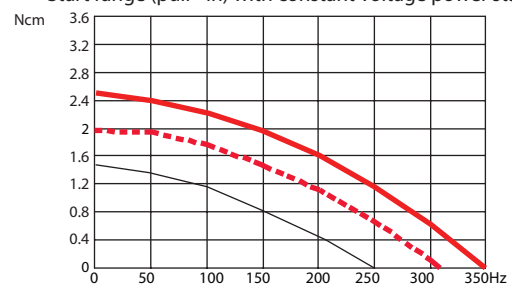

2-Phase stepper Motor MTSB5

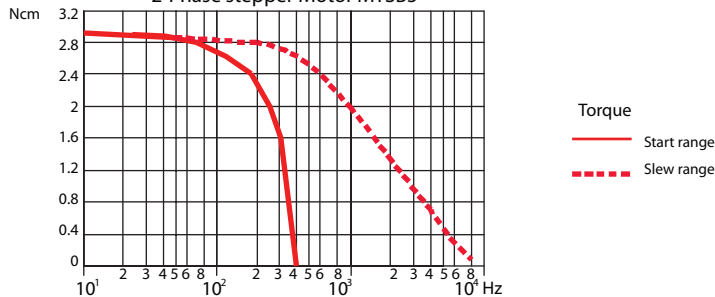

Slew range (pull-out) and start range (pull-in) with constant current power stage (chopper Drive)

4-Phase stepper Motor MTSU5

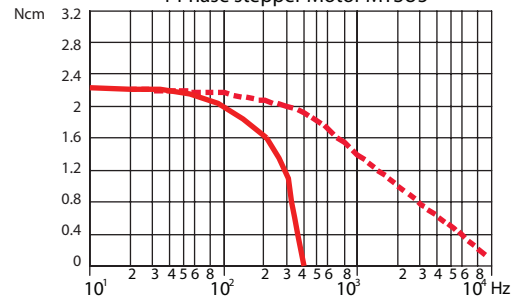

Slew range (pull-out) and start range (pull-in) with constant current power stage (chopper Drive)

Motor Series MTS4a

Stepper Motor 7.5°

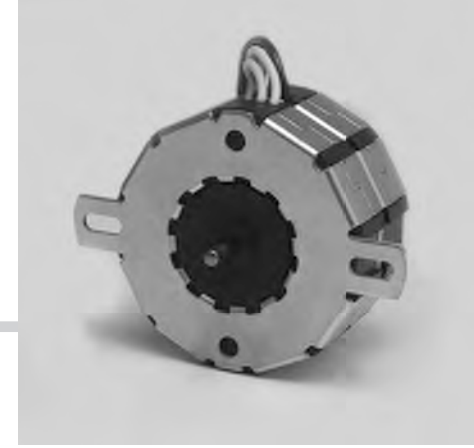

Standard Data

Motor type		Permanent Magnet (PM) stepper motor
Electrical Enclosure	IP 40	
Connections		Flexible Leads 22 AWG, 200mm length; ends stripped
Life expectancy		3 years in continuous operation
Weight	g	200
Mounting		Any position by ears or screw clip

Drawing

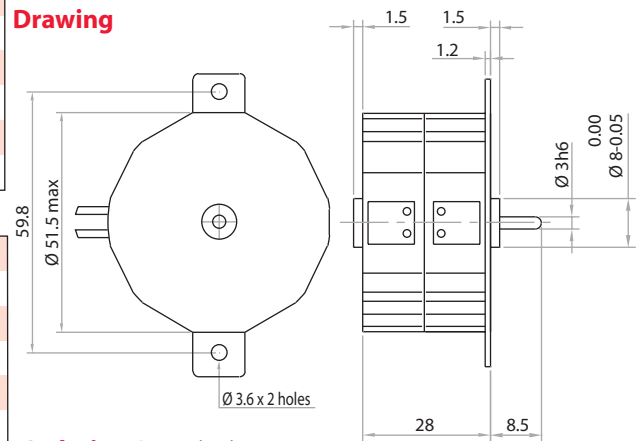

Ordering Data (eg.)

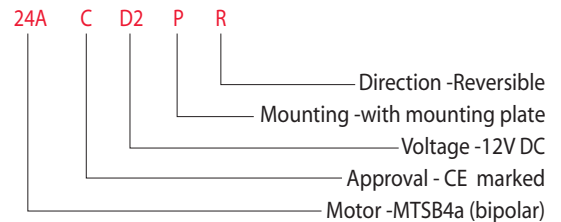

Technical Data

Steps per revolution				48
Degree/step				7.5
Winding Type				bipolar
Standard Voltage	V	6	12	24
Resistance per winding	Ω	9.5	61	251
Winding Type				unipolar
Standard Voltage	V	6	12	24
Resistance per winding	Ω	15	61	251
Winding temperature	$^{\circ}\text{C}$			105 max.
Holding torque	N-cm	5	(MTSB4a)	3.6 (MTSU4a)
Axial Force	N			3
Lateral Force	N			6
Rotor inertia	g-cm ²			6

Torque Graphs

Start range (pull - in) with constant voltage power stage

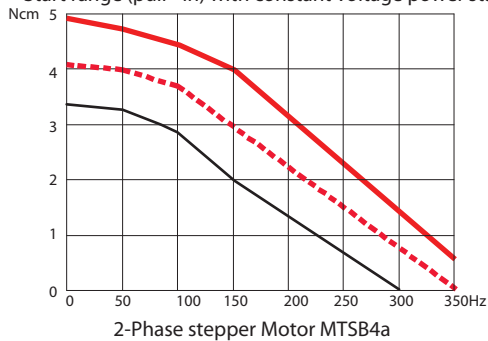

Start range (pull - in) with constant voltage power stage

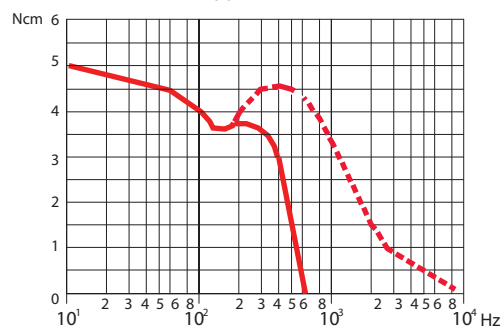
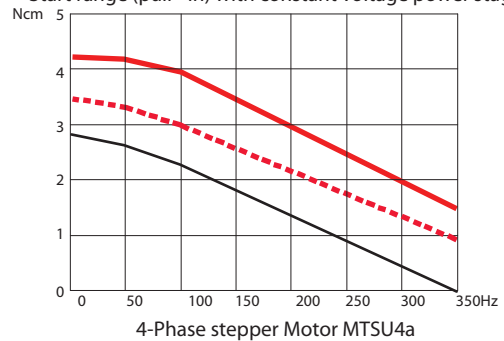

Slew range (pull-out) and start range (pull-in) with constant current power stage (chopper Drive)

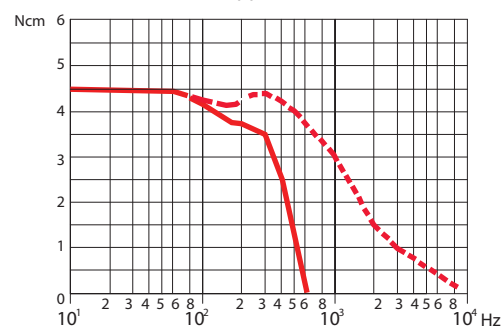

Slew range (pull-out) and start range (pull-in) with constant current power stage (chopper Drive)

Motor Series **MTS4b**

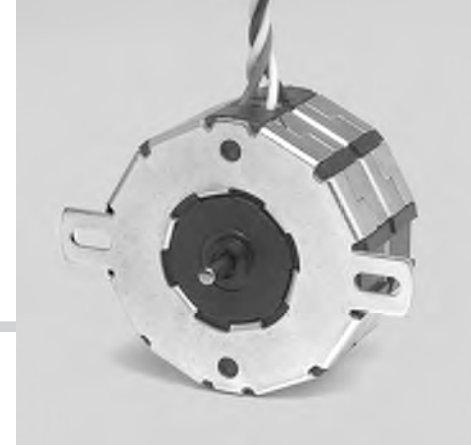

Stepper Motor 15°

Standard Data

Motor type		Permanent Magnet (PM) stepper motor
Electrical Enclosure	IP	40
Connections		Flexible Leads 22 AWG, 200mm length; ends stripped
Life expectancy		3 years in continuous operation
Weight	g	200
Mounting		Any position by ears or screw clip

Technical Data

Steps per revolution				24
Degree/step				15
Winding Type				bipolar
Standard Voltage	V	6	12	24
Resistance per winding	Ω	9.5	61	251
Winding Type				unipolar
Standard Voltage	V	6	12	24
Resistance per winding	Ω	15	61	251
Winding temperature	$^{\circ}\text{C}$			105 max.
Holding torque	N-cm	4.5	(MTSB4b)	3.2 (MTSU4b)
Axial Force	N			3
Lateral Force	N			6
Rotor inertia	g-cm ²			13

Drawing

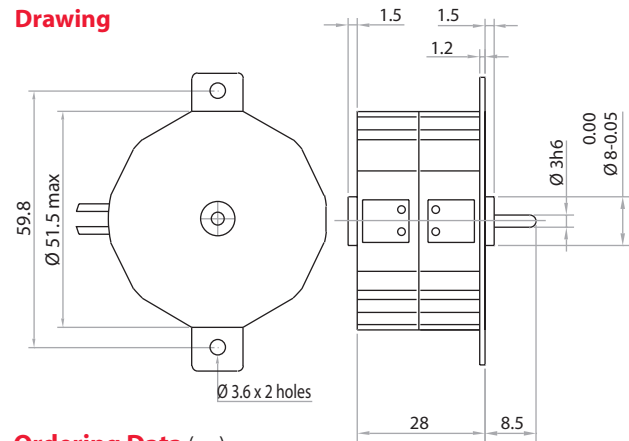

Ordering Data (eg.)

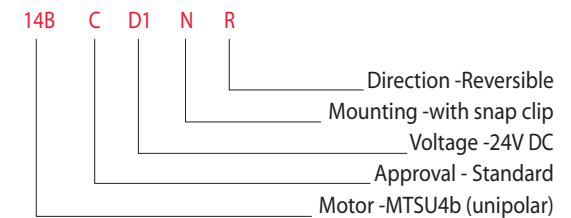

Torque Graphs

Start range (pull - in) with constant voltage power stage

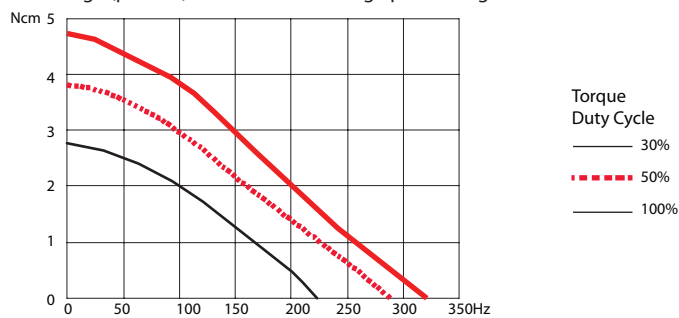

2-Phase stepper Motor MTSB4b

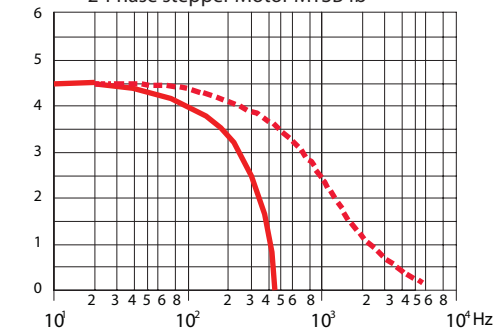

Slew range (pull-out) and start range (pull-in) with constant current power stage (chopper Drive)

Start range (pull - in) with constant voltage power stage

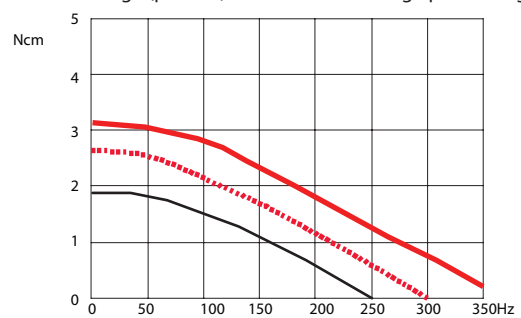

4-Phase stepper Motor MTSU4b

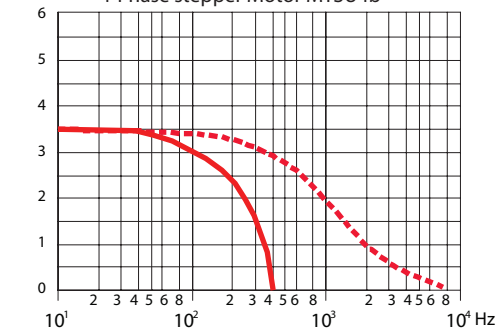

Slew range (pull-out) and start range (pull-in) with constant current power stage (chopper Drive)

Motor Series **MTSD4b**

Stepper Motor 15°



Standard Data

Motor type		Permanent Magnet (PM) stepper motor
Electrical Enclosure	IP	40
Connections		Flexible Leads 22 AWG, 200mm length; ends stripped
Life expectancy		3 years in continuous operation
Weight	g	400
Mounting		Any position by ears or screw clip

Technical Data

Steps per revolution				24
Degree/step				15
Winding Type				bipolar
Standard Voltage	V	6	12	24
Resistance per winding	Ω	5	26	122
Winding Type				unipolar
Standard Voltage	V	6	12	24
Resistance per winding	Ω	8	30	122
Winding temperature	$^{\circ}\text{C}$			105 max.
Holding torque	N-cm	8	(MTSDB4b)	6 (MTSDU4b)
Axial Force	N			3
Lateral Force	N			6
Rotor inertia	g-cm ²			26

Drawing

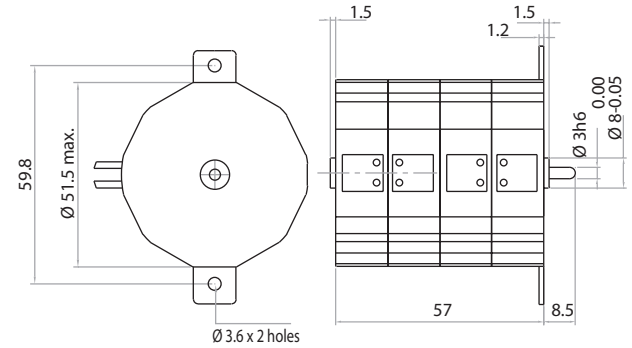

Ordering Data (eg.)

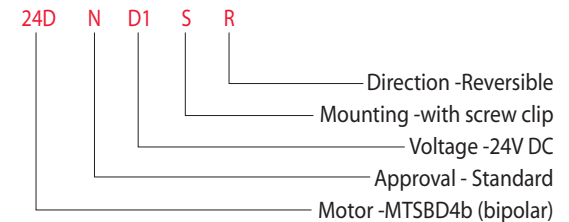

Torque Graphs

Start range (pull - in) with constant voltage power stage

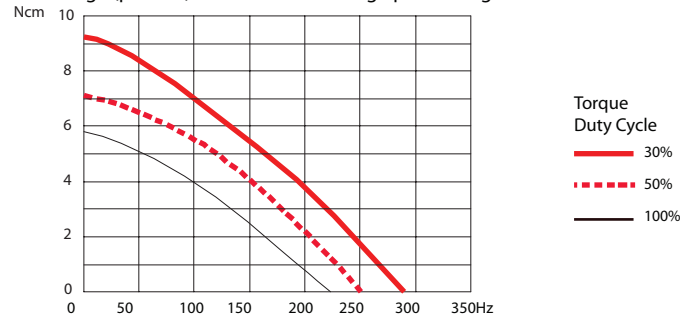

Start range (pull - in) with constant voltage power stage

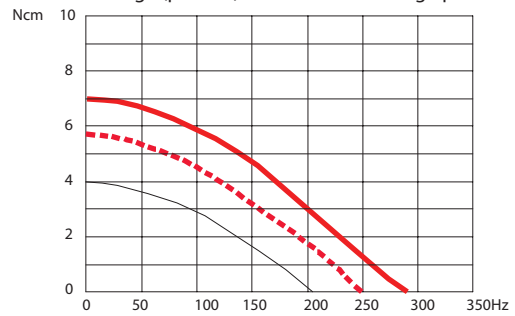

2-Phase stepper Motor MTSB4b

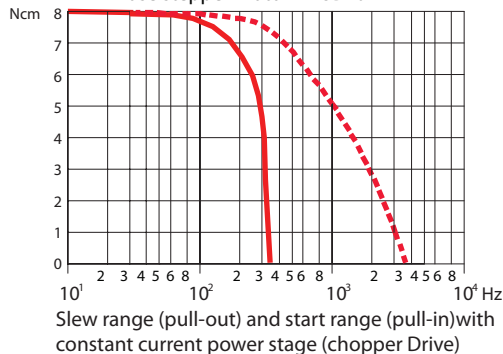

4-Phase stepper Motor MTSDU4b

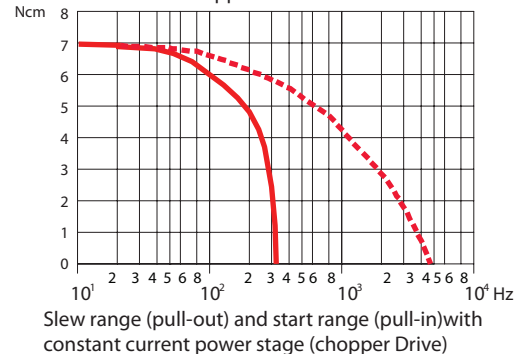

Motor Series MTS7a

Stepper Motor 7.5°



Standard Data

Motor type		Permanent Magnet (PM) stepper motor
Electrical Enclosure	IP	40
Connections		Flexible Leads 22 AWG, 200mm length; ends stripped
Life expectancy		3 years in continuous operation
Weight	g	300
Mounting		Any position by ears or screw clip

Technical Data

Steps per revolution		48		
Degree/step		7.5		
Winding Type		bipolar		
Standard Voltage	V	6	12	24
Resistance per winding	Ω	6.8	36	168
Winding Type		unipolar		
Standard Voltage	V	6	12	24
Resistance per winding	Ω	10	45	190
Winding temperature	$^{\circ}\text{C}$	105 max.		
Holding torque	N-cm	17.1	(MTSB7a)	13 (MTSU7a)
Axial Force	N	5		
Lateral Force	N	12		
Rotor inertia	g-cm ²	65		

Drawing

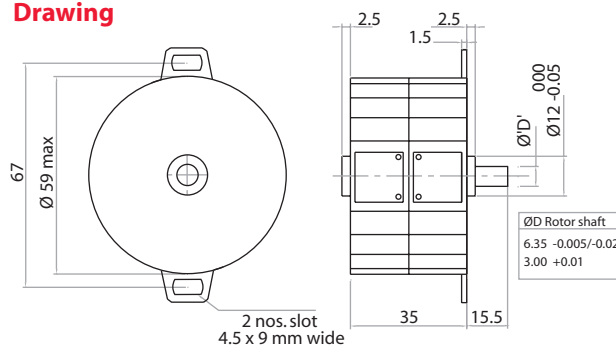

Ordering Data (eg.)

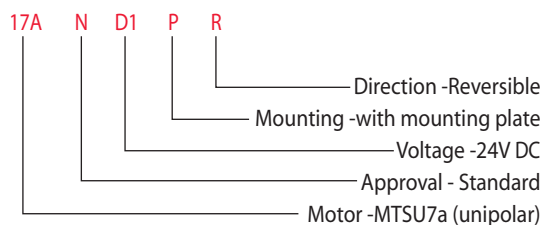

Torque Graphs

Start range (pull - in) with constant voltage power stage

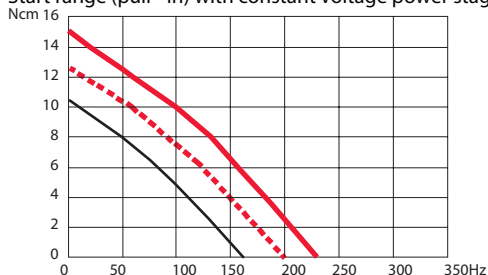

Start range (pull - in) with constant voltage power stage

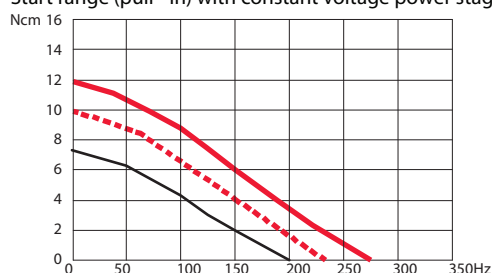

2- PHASE STEPPER MOTOR MTSB7a

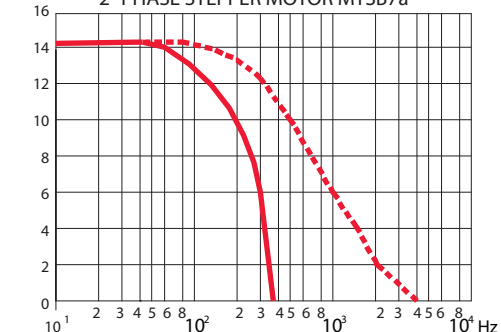

Slew range (pull-out) and start range (pull-in) with constant current power stage (chopper Drive)

4- PHASE STEPPER MOTOR MTSB7a

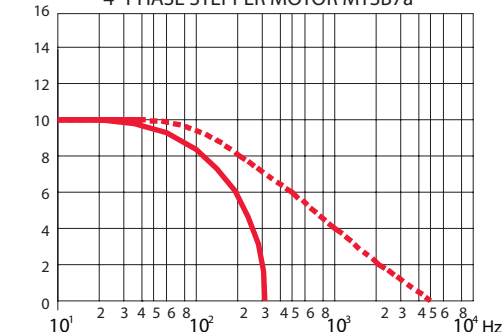

Slew range (pull-out) and start range (pull-in) with constant current power stage (chopper Drive)

Motor Series **MTS8c**



Stepper Motor 11.25°

Standard Data

Motor type		Permanent Magnet (PM) stepper motor
Electrical Enclosure	IP	40
Connections		Flexible Leads 22 AWG, 200mm length; ends stripped
Duty cycle		Continuous
Weight	g	450
Mounting		Any position by ears or screw clip

Technical Data

Steps per revolution		32		
Degree/step		11.25		
Winding Type		bipolar		
Standard Voltage	V	4.5		
Resistance per winding	Ω	4.0		
Winding temperature	$^{\circ}\text{C}$	130 max.		
Magnet type		Regular		Strong
Holding torque	N-cm	30	(MTSB8c) 45	(MTSB8c-RE)
Axial Force	N	6		6
Lateral Force	N	15		15
Detent torque	Ncm	2.5		7.5
Rotor inertia	g-cm ²	155		180

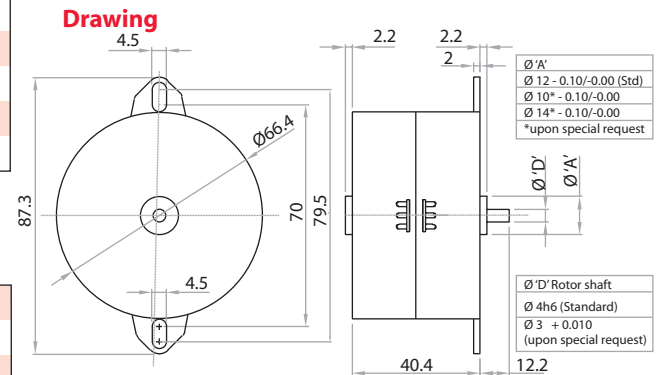

Ordering Data (eg.)

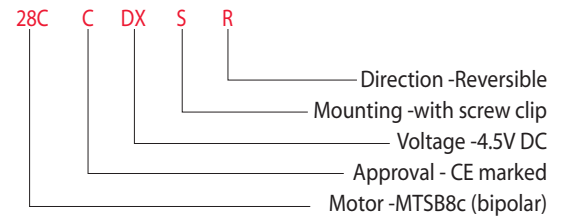

Torque Graphs

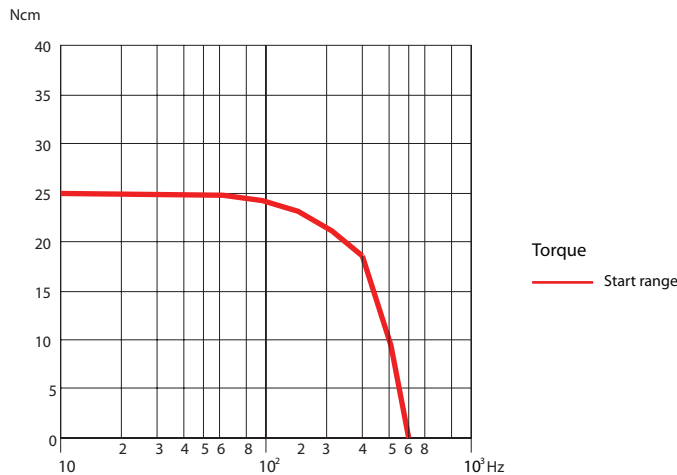

Regular Magnet Start Range (pull-in) with constant current power stage (chopper Drive)

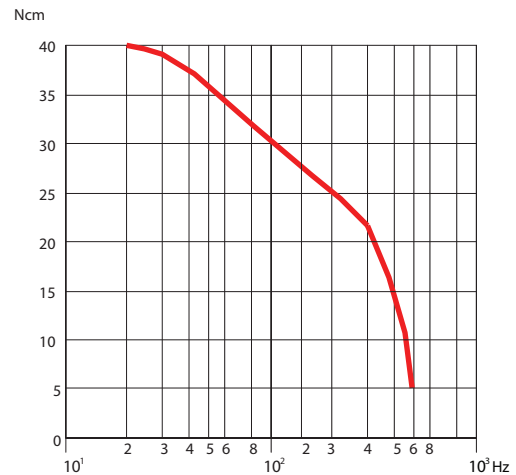

Strong Magnet Start Range (pull-in) with constant current power stage (chopper Drive)

Gear Series **GB380CP**



Spur Reduction Gearhead - 0.5 Nm

Design

Gearhead GB380CP is a multi step gearhead with all polyacetal gears which rotate on steel spindles which are polished to a mirror-finish and introduced between metal plates with a plastic frame. All bearings are permanently lubricated and therefore require no maintenance. Thicker shafts ($\varnothing 6-7\text{mm}$) mounted in robust bushings ($\varnothing 12$) are available. Similarly the gears at the output end can be metal (GB380CPH) with thick shafts ($\varnothing 6-7\text{mm}$) & robust bushings. Sintered gears variant also possible (GB380CSi).

Standard Data

Gear Type		Spur
Gear Torque	Nm	0.5
Combination with Mechtex motors		small DC motors up to dia. 35mm (DC28/30/32) & MTR3a/3b, MTS3a/3b
Mounting		any position
Weight	g	55
Axial thrust	N	20
Lateral force	N	60
Radial torque	Nm	0.6
Output bearing		Brass sleeve bushings, Sintered bronze (on request)
Output shafts	\varnothing	all shafts same as GB5P gear series
Ambient temperature operation	$^{\circ}\text{C}$	-15...+55
Enclosure	IP	30

Transmission Ratios

For Transmission Ratios refer to page nos. 6 & 7.

Dimensional Drawing

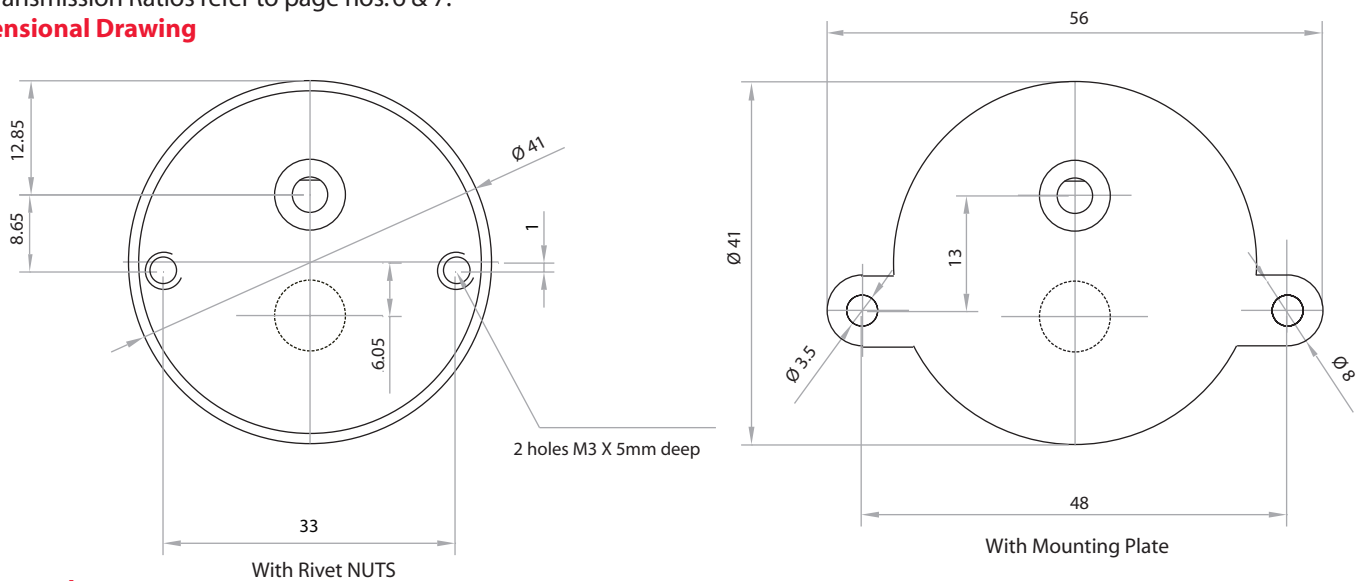

Photographs

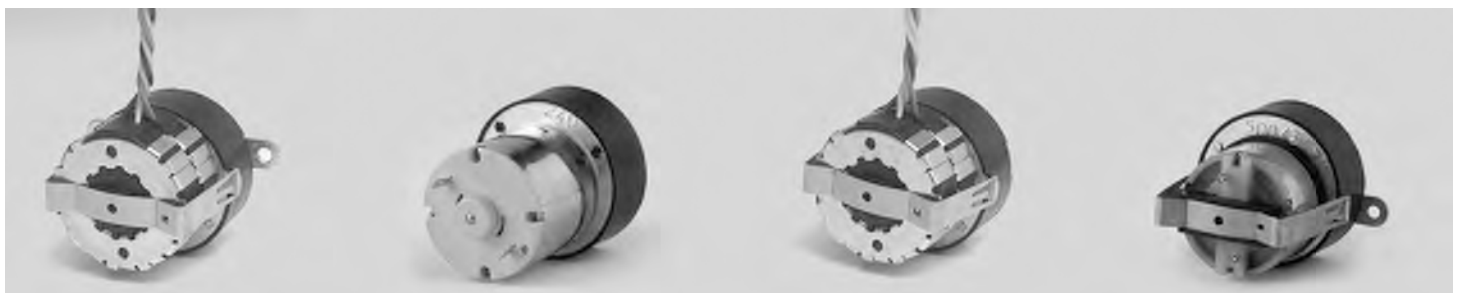

Gear Series GB2

Spur Reduction Gearhead - 0.3 Nm



Design

In GB2 gearhead, spur gears rotate on hardened steel spindles which are polished to a mirror finish. In order to damp running noise at slow running times and low motor loads, the initial spur gears after the rotor shaft are made of injection moulded poly acetal. The spur gears close to the output shaft on the other hand, are made of metal. The output shaft is mounted in two special brass bushes. The entire gear train is put between metal plates with a plastic frame. It is permanently lubricated and therefore requires no maintenance. Thicker shaft (Ø6-7mm) mounted in robust bushings (Ø12) are available in a new variant (GB2S). Single-way or two way slipping clutches can also be installed to enable the output shaft to be rotated while the motor is stationary. GB2 can also be combined with small DC Motors. To achieve higher gear torque, GB2 can be mounted on GB4, GBW & GBX.

Technical Data

Gear Type		Spur Reduction
Gear Torque	Nm	0.3
Combination with Mechtex motors		Motor MT0, MT6, MTR/S3a/3b, MTR/S-5 and small DC motors
Mounting		any position
Weight	g	60
Axial thrust	N	20
Lateral force	N	50
Radial torque	Nm	0.5
Slipping clutches/free wheel		single left/right
Slipping clutches/friction 2 way	Nm	0.05
Output bearing		Brass sleeve bushings, Sintered bronze (on request)
Output shafts	Ø	3.175, 4.00, 4.76, 5.00, 6.00 & 7..00 (others on request)
Ambient temperature operation	°C	-15...+ 55
Enclosure	IP	40

Transmission Ratio

For Transmission Ratios refer to page nos. 6 & 7.

Torque/Transmission Ratio/Life graph

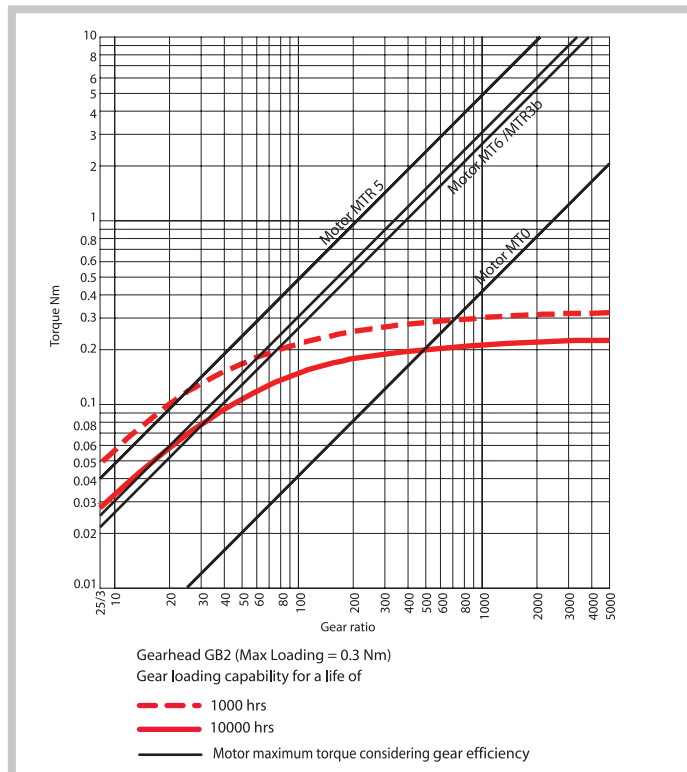

Dimensional Drawing

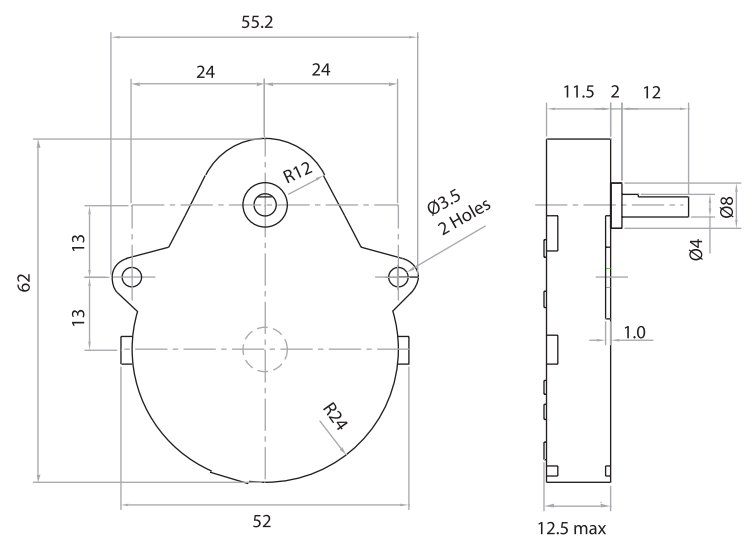

Gear Series GB2

Spur Reduction Gearhead - 0.3 Nm

Shaft type catalogue

Shaft type	Shaft Diam.										
	D	H(+)	L	d	l	d'	P	M	T	h	C
S	6.35*	2	12	3.175	9	2.8					
A	8	2	9	3.175	6	2.8					
B	8	2	16	3.175	13	2.8					
C	8	2	21	3.175	18	2.8					
D	8	2	12	4	9	3.6					
E	8	2	16	4	13	3.6					
F	8	2	21	4							
G	6.35*	2	12	4.764	9	4.2					
H	6.35*	2	16	4.764	13	4.2					
I	6.35*	2	20	4.764	11	4.2					
J	6.35*	2	22	4.764	13	4.2					
K	6.35*	2	25.5	4.764	19	4.2					
L	6.35*	2	8	4.764	6	4.2					
M	6.35*	2	12	4.764	11.5				1/8"		
N	8	2	12	6.35	7		3				
O	8	2	21	4	10					2	
P	8	2	10	4							
Q	8	3.5	19	5	5.5					2	
R	12	3	15	6	10	5.4					
T	12	3	21	6	16	5.4					
U	12	3	26	6	18	5.4					
V	12	3	52	6							
W	12	3	22	7	17	6	9				M4
X	12	3	15	7	10	6.3					
Y	12	3	21	7	15	5					
Z	12	3	21	7							
a	12	3	26	7	18	6.3					
b	12	3	52	7							
c	12	3	39.5	7	34	5.4					

Shaft Drawing

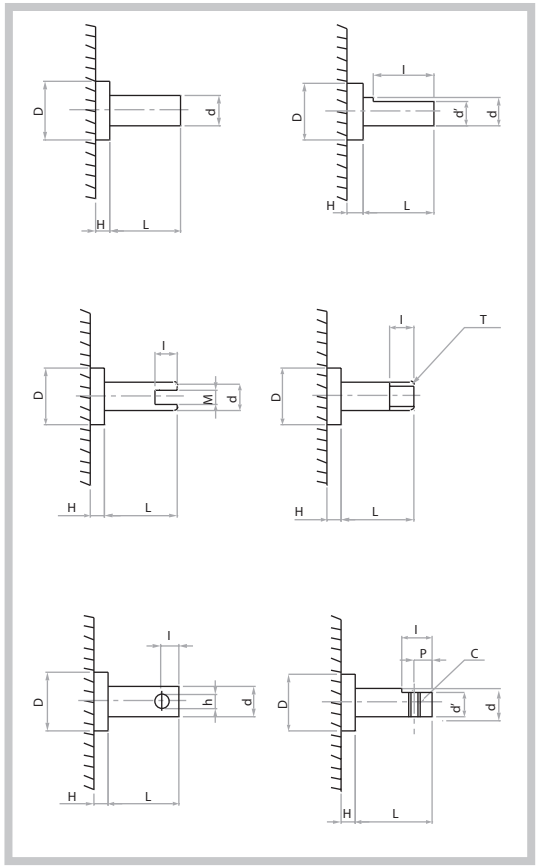

Note: '+' 3.5 mm also possible '*' 8 mm also possible

Drawings

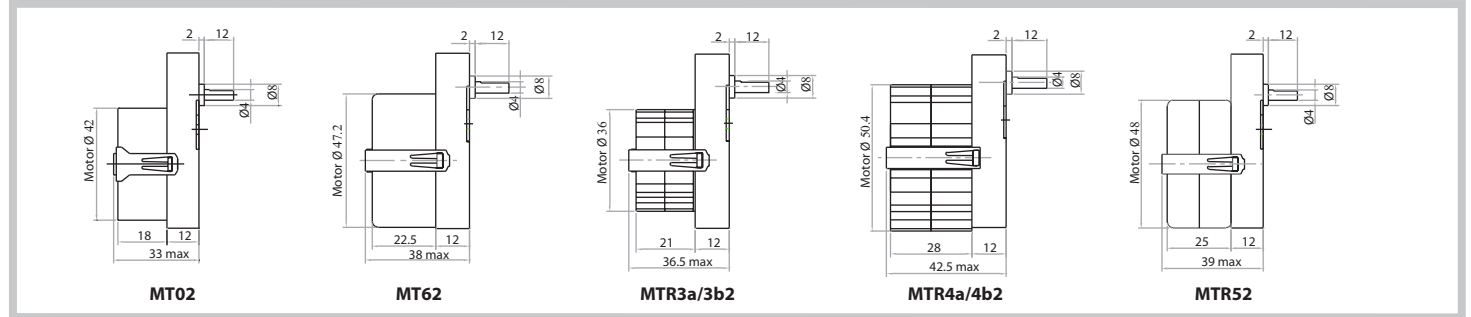

Photographs



Gear Series GB5P

Spur Reduction Gearhead - 0.5 Nm



Design

Gearhead GB5P, the most popular gearhead, is a multi step gear box with all polyacetal gears which rotate on steel spindles which are polished to a mirror-finish and introduced between metal plates with a plastic frame. All bearings are permanently lubricated and therefore require no maintenance. Motor is attached to the gear box by means of spring clip. Thicker shafts (Ø6-7mm) mounted in robust bushings (Ø12mm) are available (GB5PS). Similarly the gears at the output end can be metal (GB5PH) with thick shafts & robust bushings (GB5PHS). Sintered gears variant also possible (GB5Si) GB5P can also be combined with small DC Motors. To achieve higher gear torque, GB5P can be mounted on GB4, GBW & GBX

Technical Data

Gear Type		Spur Reduction
Gear Torque	Nm	0.5
Combination with Mechtex motors		Motor MT0, MT6, MTR/S3a/3b, MTR/S4a/4b and small DC motors
Mounting		any position
Weight	g	60
Axial thrust	N	20
Lateral force	N	50
Radial torque	Nm	0.6
Slipping clutches/free wheel		available for certain ratios
Output bearing		Brass sleeve bushings, Sintered bronze (on request)
Output shafts	Ø	3.175, 4.00, 4.76, 5.00, 6.00 & 7.00 (others on request)
Ambient temperature operation	°C	-15...+ 55
Enclosure	IP	40

Torque/Transmission Ratio/Life graph

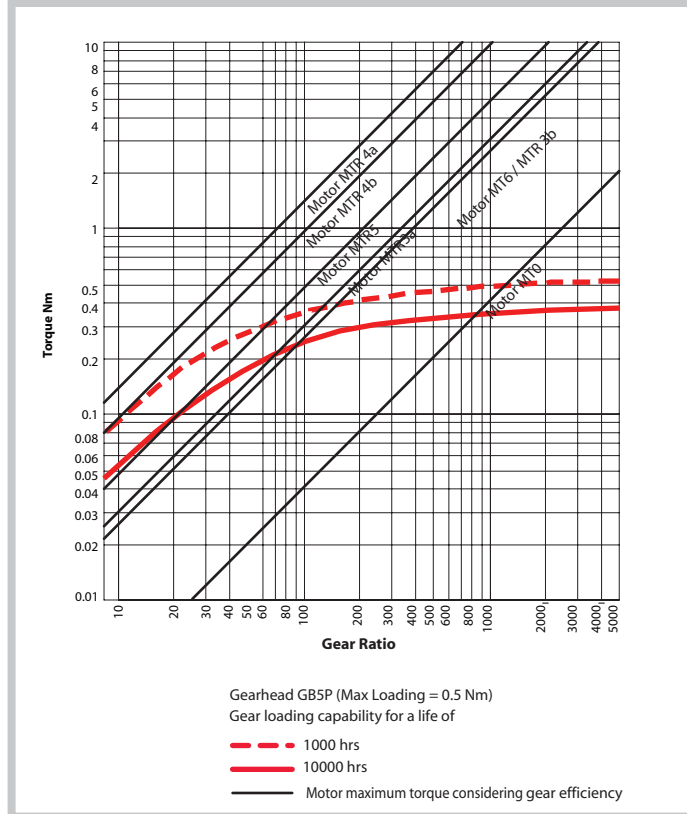

Transmission Ratios

For Transmission Ratios refer to page nos. 6 & 7.

Dimensional Drawing

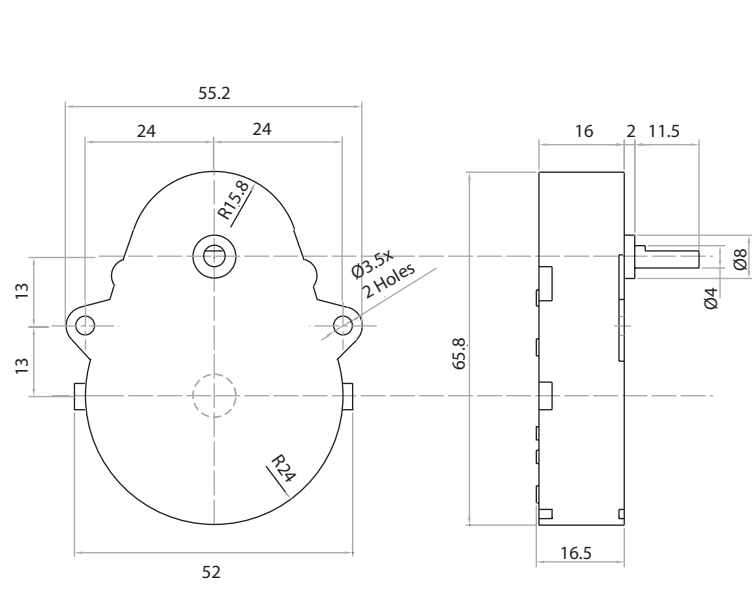

Gear Series GB5P

Spur Reduction Gearhead - 0.5 Nm

Shaft type catalogue

Shaft type	Shaft Diam.		Shaft Diam.									
	D	H(+)	d	L	l	d'	l'	L'	R	Q	M	h
S	8	2	4	11.5	9	3.6						
B	8	2	4	26.5	24.5	3.6						
C	8	2	4	11.5	9	3						
D	8	2	4	7	4.5	3.6						
E	8	2	4	38	36	3.6						
F	8	2	4	16.5	14	3						
G	8	2	1/8"	11.5	9	2.8						
H	8	2	1/8"	16.5	14	2.8						
I	8	2	1/8"	21.5	17	2.8						
J	8	2	4	11.5	4							2
K	8	2	4	11.5	6.8							1.4
L	8	2	4	21.5	17	3.6						
M	8	2	3/16"	11.5	9	4.2						
N	8	2	3/16"	21.5	17	4.2						
O	8	2	3/16"	26.5	22	4.2						
U	8	2	3/16"	16.5	12	4.2						
V	8	2	4	10.5	9	3.6	20	35.5	3.6	4		
W	12	3	6	11.5	10	4.5						
X	12	3	6	21	18	5.4						
Y	12	3	6	52								
Z	12	3	7	13	10	6						
a	12	3	8	13	10	6						
b	12	3	6	20.5	10	5						
c	12	3	6	13.5	10.5	5.4						
d	12	3	6	36	30	5.4						
e	12	3	8	21	16	7.2						
f	12	3	6	11.5	5							2
g	12	3	6	80	20							2
h	12	3	7	18.7	4.5							3
i	12	3	6	11.5	3.5							3
m	12	3	7	16	10						3	

Shaft Drawing

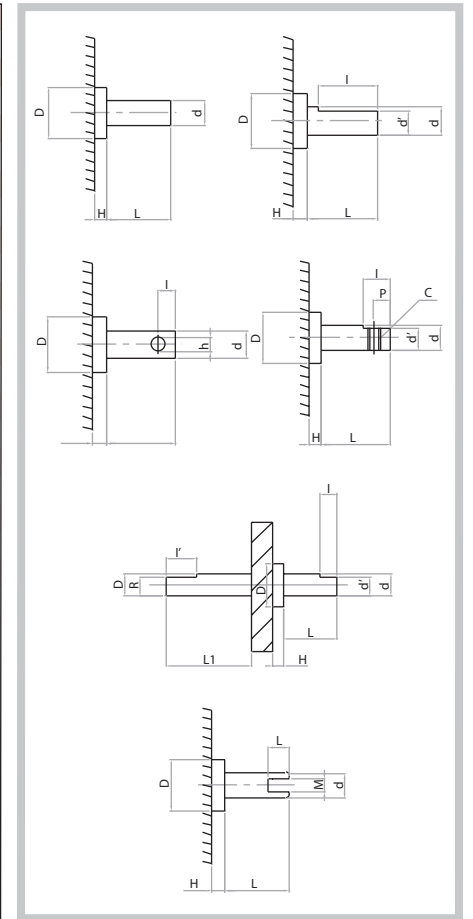

Note: '+' 3.5 mm also possible

Drawing

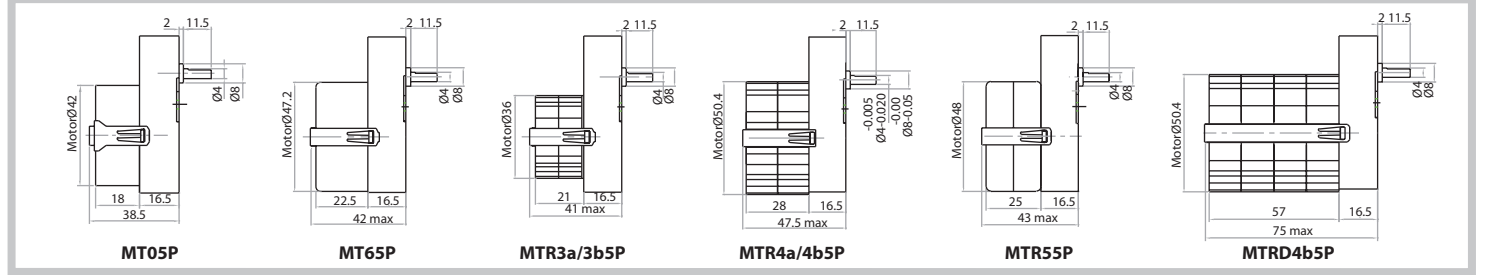

Photographs



Gear Series GB5H

Spur Reduction Gearhead - 1 Nm



Design

Gearhead GB5H, a moderately priced gearhead, is specially designed to cater to heavy duty application in a small frame. This is a multi step gear box with all thick metal gears that rotate on steel spindles which are polished to a mirror-finish and introduced between metal plates with a plastic frame. All bearings are permanently lubricated and therefore require no maintenance. Motor is attached to the gear box by means of spring clip. Thicker shafts (Ø6-7mm) mounted in robust bushings (Ø12mm) are available in a new variant (GB5H). GB5H can also be combined with small DC Motors, To achieve higher gear torque, GB5H can be mounted on GB4, GBW & GBX

Standard Data

Gear Type		Spur Reduction
Gear Torque	Nm	1
Combination with Mechtex motors		MT0,MT6,MTR/S3a/3b,MTR/S-5,MTR/S4a/4b and small DC motors
Mounting		any position
Weight	g	65
Axial thrust	N	20
Lateral force	N	100
Radial torque	Nm	1.5
Slipping clutches/free wheel		not available
Output bearing		Brass sleeve bushings, Sintered bronze (on request)
Output shafts	Ø	3.175,4.00,4.76,5.00,6.00 & 7..00 (others on request)
Ambient temperature operation	°C	-15...+ 55
Enclosure	IP	40

Torque/Transmission Ratio/Life Graph

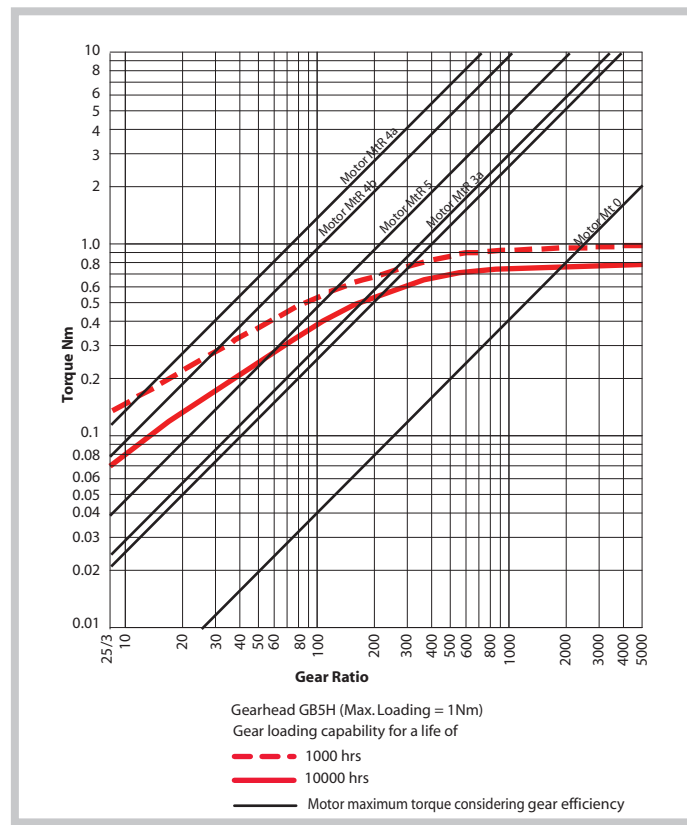

Gear Series GB5H

Spur Reduction Gearhead - 1 Nm

Shaft Type Catalogue

Shaft type	D	H(+)	Shaft Diam. d	L	l	d'	P	M	T	h	C
S	6.35*	2	3.175	12	9	2.8					
A	8	2	3.175	9	6	2.8					
B	8	2	3.175	16	13	2.8					
C	8	2	3.175	21	18	2.8					
D	8	2	4	12	9	3.6					
E	8	2	4	16	13	3.6					
F	8	2	4	21							
G	6.35*	2	4.764	12	9	4.2					
H	6.35*	2	4.764	16	13	4.2					
I	6.35*	2	4.764	20	11	4.2					
J	6.35*	2	4.764	22	19	4.2					
K	6.35*	2	4.764	25.5	20	4.2					
L	6.35*	2	4.764	8	6	4.2					
M	8	2	3.175	12	11.5				1/8"		
N	8	2	6.35	12	7			3			
O	8	2	4	21	10					2	
P	8	2	4	10							
Q	8	3.5	5	19	5.5					2	
R	12	3	6	15	10	5.4					
T	12	3	6	21	16	5.4					
U	12	3	6	26	18	5.4					
V	12	3	6	52							
W	12	3	7	22	17	6	9				M4
X	12	3	7	15	10	6.3					
Y	12	3	7	21	15	5					
Z	12	3	7	21							
a	12	3	7	26	18	6.3					
b	12	3	7	52							
c	12	3	7	39.5	34	5.4					

Shaft Drawings

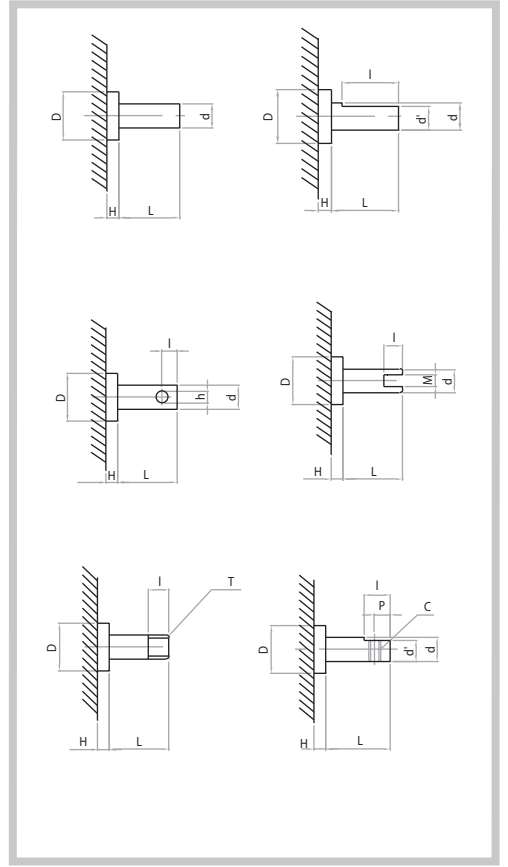

Note: '+' 3.5 mm also possible

Transmission Ratios

For Transmission Ratios refer to page nos. 6 & 7.

Dimensional Drawing

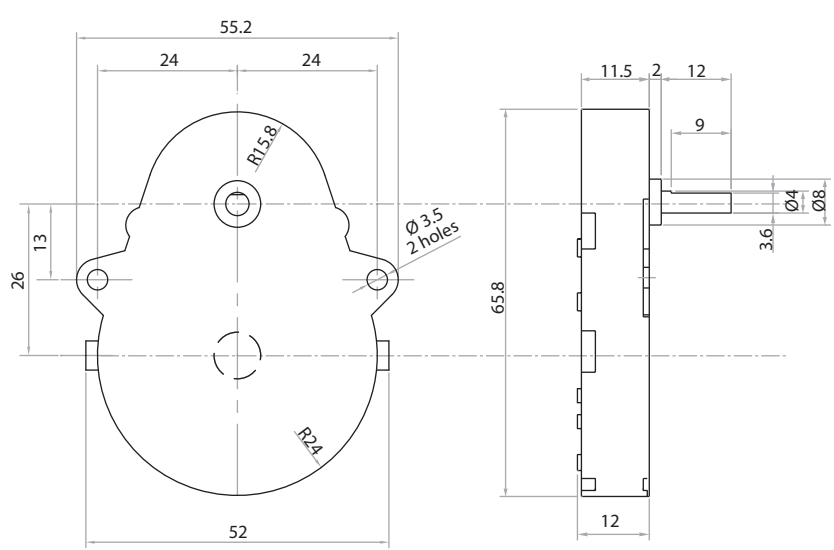

Drawings

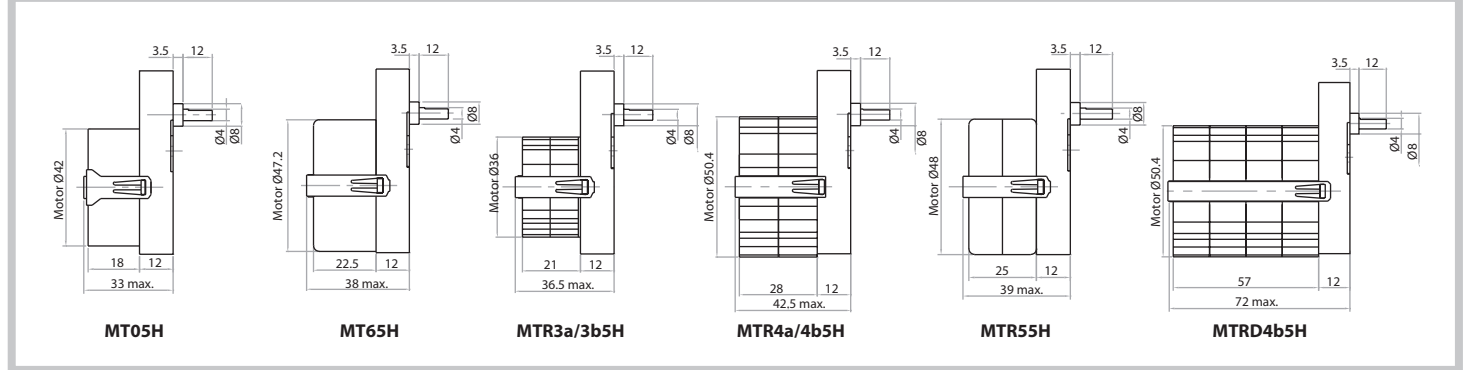

Photographs



Gear Series GB3/8

Spur Reduction Gearhead - 5 Nm



Design

Gearhead GB3/8 contains heavily loaded steel gear wheels. The spur gears rotate on fixed steel spindles which are hardened and polished to a mirror finish. The thick output shaft rotates in robust sintered bushings. All the gears are housed between two metal plates with a plastic frame. All bearings are permanently lubricated and therefore require no maintenance. Economical versions with poly-acetal or sintered gears available. This gear box can also be combined with small to medium sizes of DC motors.

Technical Data

Gear Type		Spur Reduction
Gear Torque	Nm	5
Combination with Mechtex motors		Motor MT0, MT6, MTR/S3a/3b, MTR/S-5, MTR/S4a/4b and small DC motors
Mounting		any position
Weight	g	200
Axial thrust	N	100
Lateral force	N	400
Radial torque	Nm	4
Slipping clutches/free wheel		available for certain ratios
Output bearing		Sintered bronze
Output shafts	Ø	dia. 8 x 17 mm (with a flat), others on request
Ambient temperature operation	°C	-15...+ 55
Enclosure	IP	30

Torque/Transmission Ratio/Life Graph

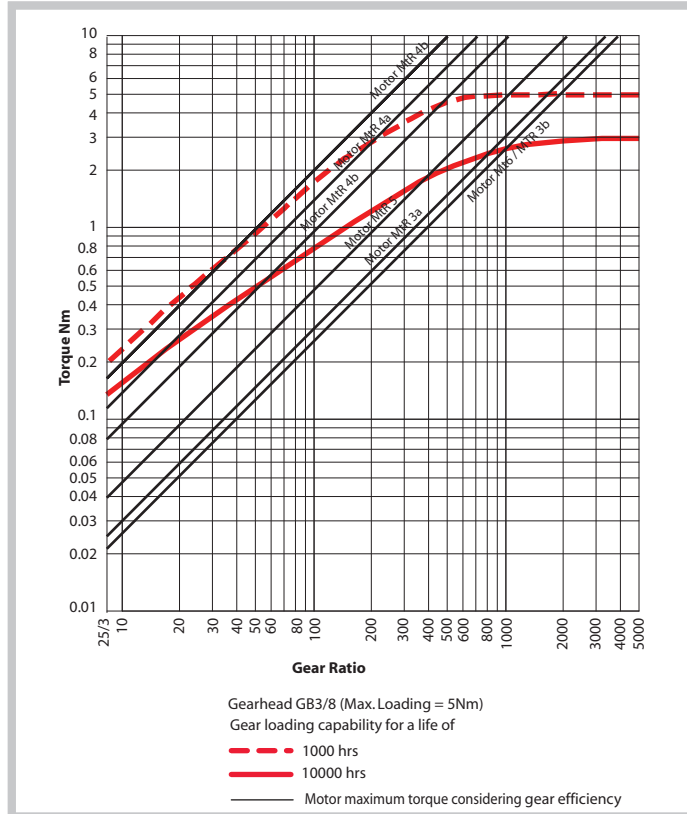

Transmission Ratios

For Transmission Ratios refer to page nos. 6 & 7.

Dimensional Drawing GB3

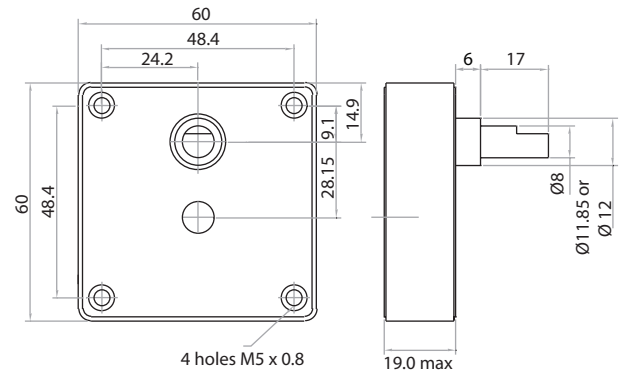

Dimensional Drawing GB8

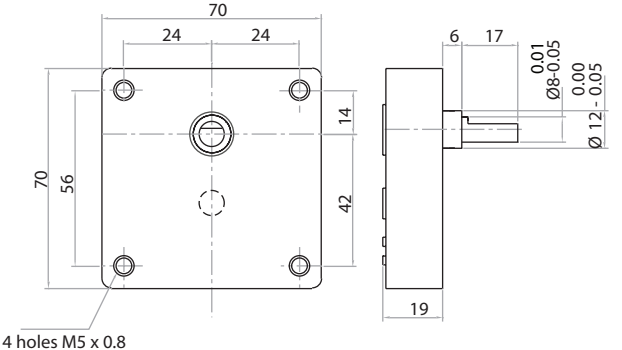

Gear Series GB3/8

Spur Reduction Gearhead - 5 Nm

Shaft Drawings

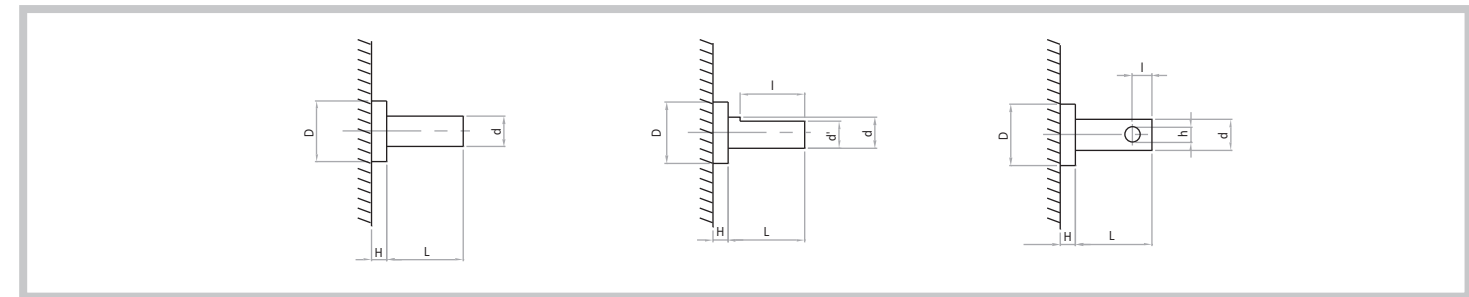

Shaft Type Catalogue

Shaft type	D	H	d (dia)	L	l	d'	h
S	12	6	8	17	8	6	
A	12	6	8	27	18	6	
C	12	6	8	17	9		3

Drawings

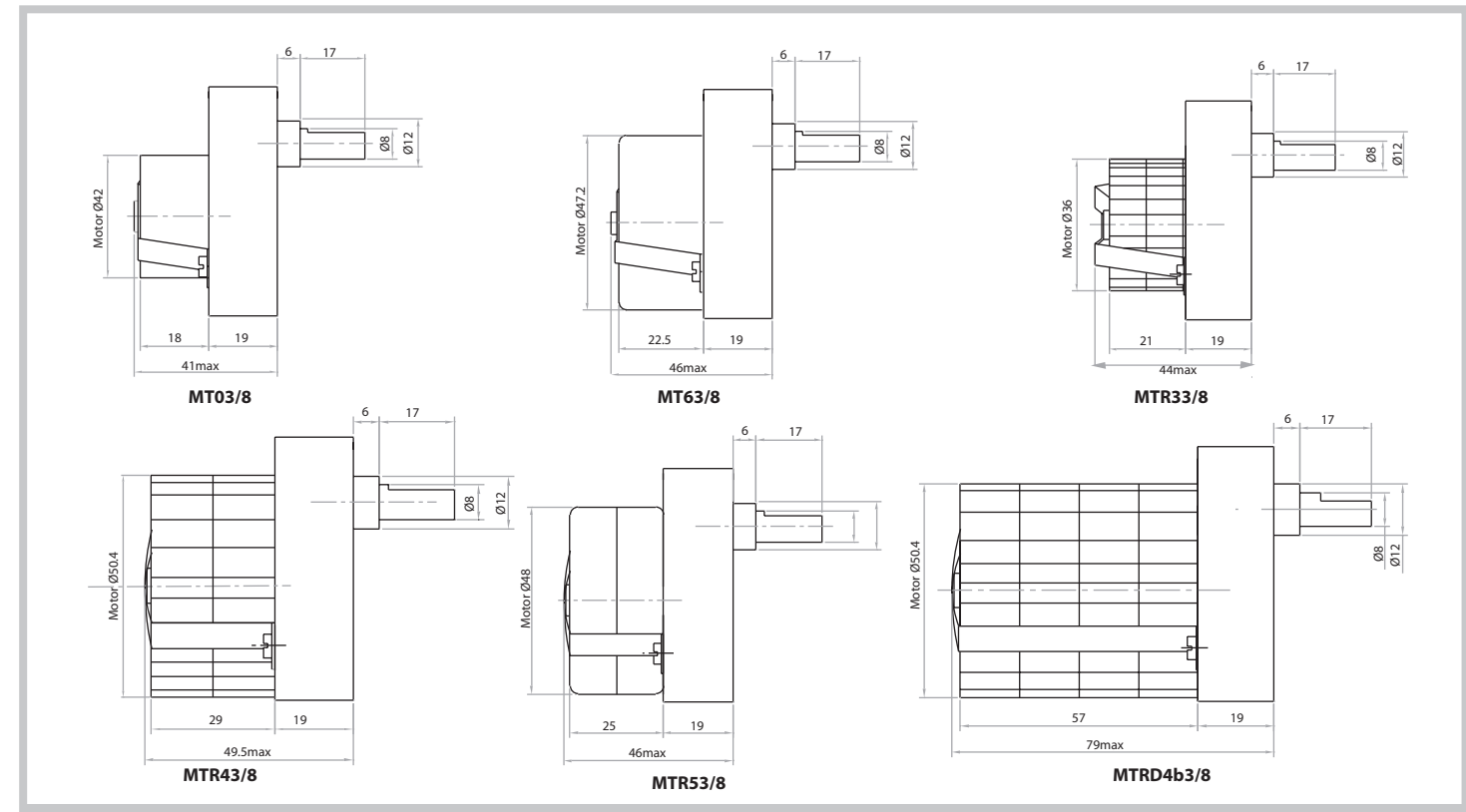

Photographs



Gear Series GB7

Spur Reduction Gearhead - 5 Nm



Design

Gearhead GB7 contains heavily loaded steel gear wheels. The spur gears rotate on fixed steel spindles which are hardened and polished to a mirror finish. The thick output shaft rotates in robust sintered bushings. All the gears are housed in a pressure die cast housing & closed by metal plates. All bearings are permanently lubricated and therefore require no maintenance. Economical versions with poly-acetal or sintered gears available. This gear box can also be combined with small to medium sizes of DC motors (upto dia 36.) Output shaft can be emerging from the rear side or both sides.

Technical Data

Gear Type		Spur Reduction
Gear Torque	Nm	5
Combination with Mechtex motors		MT0, MT6, MTR/S-5, MTR/S3a/3b, MTR/S4a/4b MTR/SD4b-RE & DC motors(upto dia38)
Mounting		any position
Weight	g	300
Axial thrust	N	100
Lateral force	N	400
Radial torque	Nm	4
Slipping clutches/free wheel		available for certain ratios
Output bearing		Sintered bronze
Output shafts	Ø	dia. 8 x 16 mm (with a flat), others on request
Ambient temperature operation	°C	-15...+ 55
Enclosure	IP	30

Torque/Transmission Ratio/Life Graph

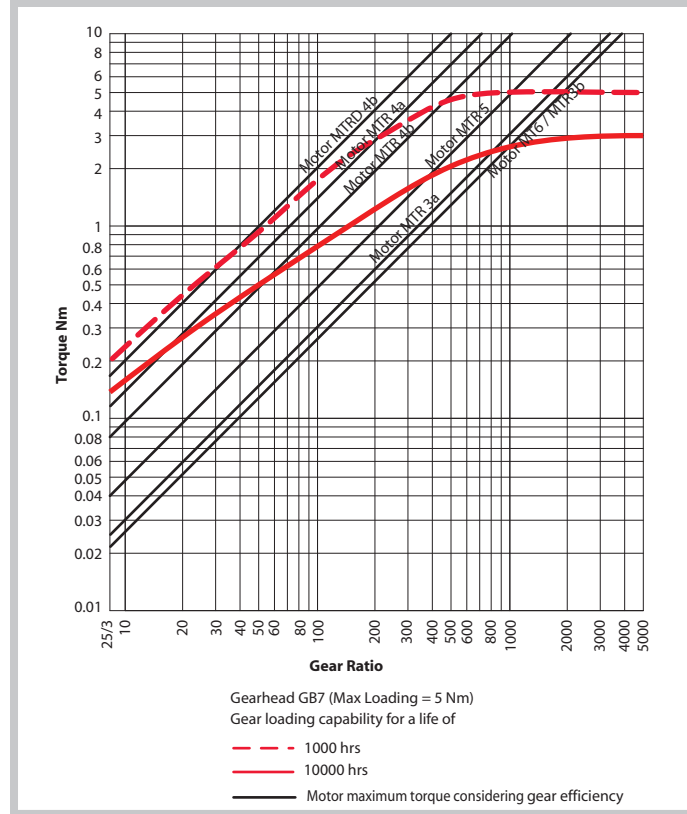

Transmission Ratios

For Transmission Ratios refer to page nos. 6 & 7.

Dimensional Drawing

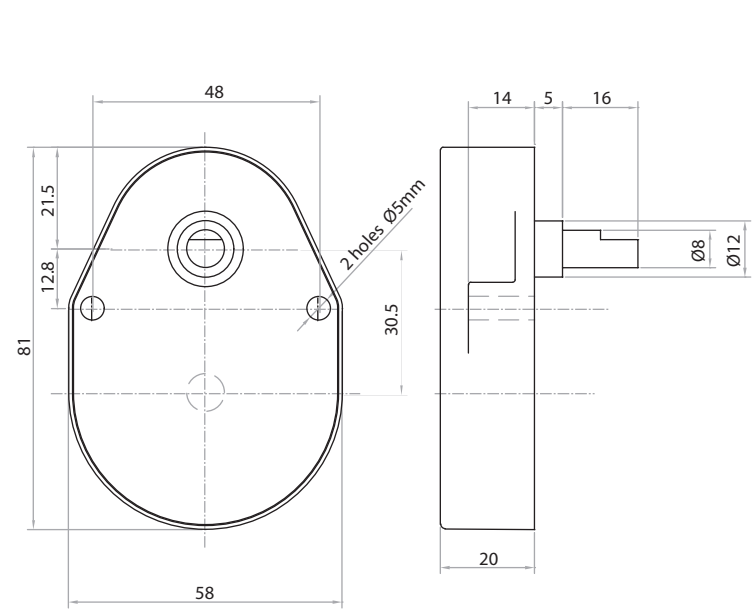

Gear Series GB7

Spur Reduction Gearhead - 5 Nm

Shaft Drawings

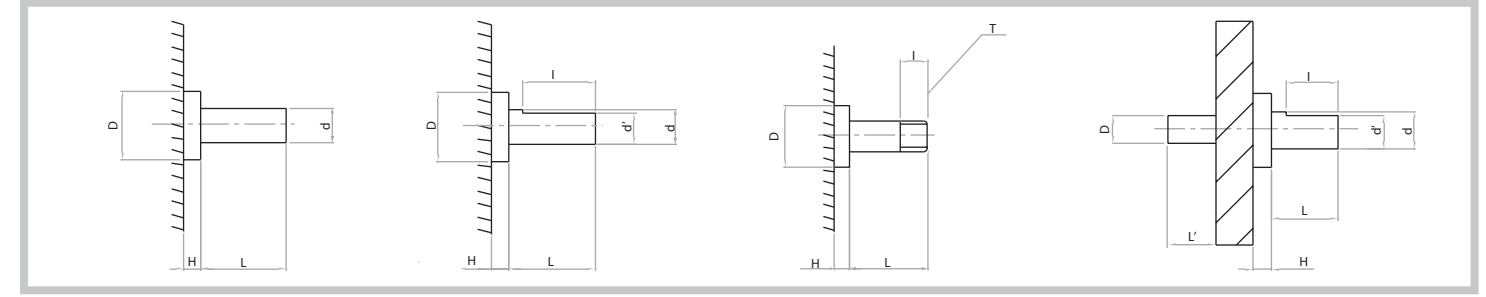

Shaft Type Catalogue

Shaft type	D	H	d (dia)	L	l	d'	h	Q	h
S	12	5	8	16	8	6			
A	12	5	8	26	18	6			
B	12	5	8	16	8	6	12.5	6.35	
C	12	5	8	16	9	6			3

Drawings

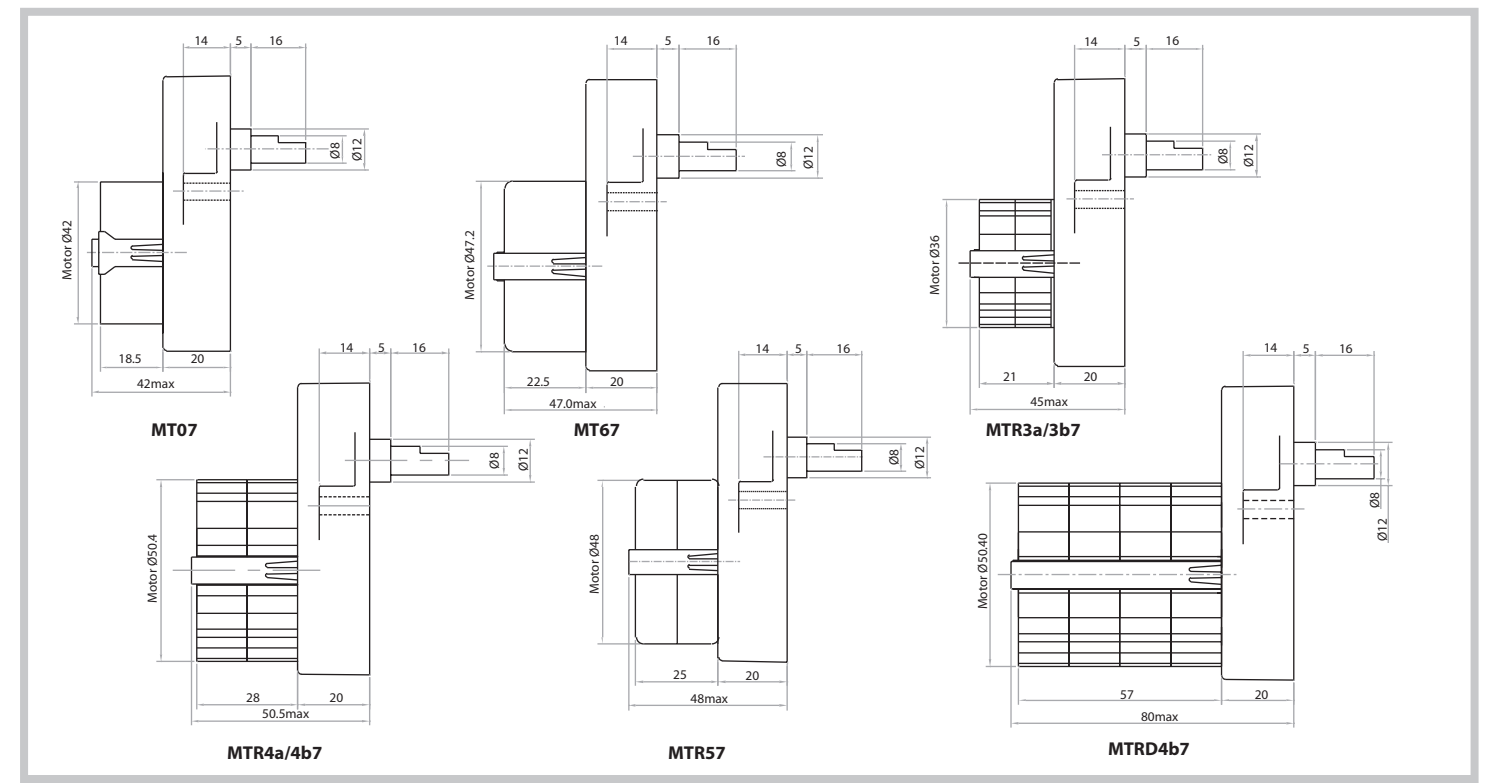

Photographs



Gear Series **GB U/V**

Spur Reduction Gearhead - 6 Nm



Design

Gearhead GBV/U contains heavily loaded steel gear wheels. The spur gears are fixed on steel spindles which are hardened and polished to a mirror finish & rotate in robust sintered bushings. The thick output shaft rotates in robust brass bushings. All the gears are housed in between metal plates & closed by plastic dust cover. All bearings are permanently lubricated and therefore require no maintenance. GBV/U can also be combined with small to medium sizes of DC motors (up to Ø52mm).

Standard Data

Gear Type		Spur Reduction
Gear Torque	Nm	6
Combination with Mechtex motors		MT0,MT6,MTR/S5,MTR/S-4a/b,MTR/SD-4,MTR/SD4-RE & DC motors (up to Ø52mm) MTR/S 7a, MTR/S 8c, MTR9a,b,d
Mounting		any position
Weight	g	350
Axial thrust	N	30
Lateral force	N	100
Radial torque	Nm	4
Output bearing		Brass sleeve bushings, Ball Bearing (on special request)
Output shafts	Ø	dia. 8 x 22 mm (with a flat), others on request
Ambient temperature operation	°C	-15...+ 55
Enclosure	IP	30

Torque/Transmission Ratio/Life Graph

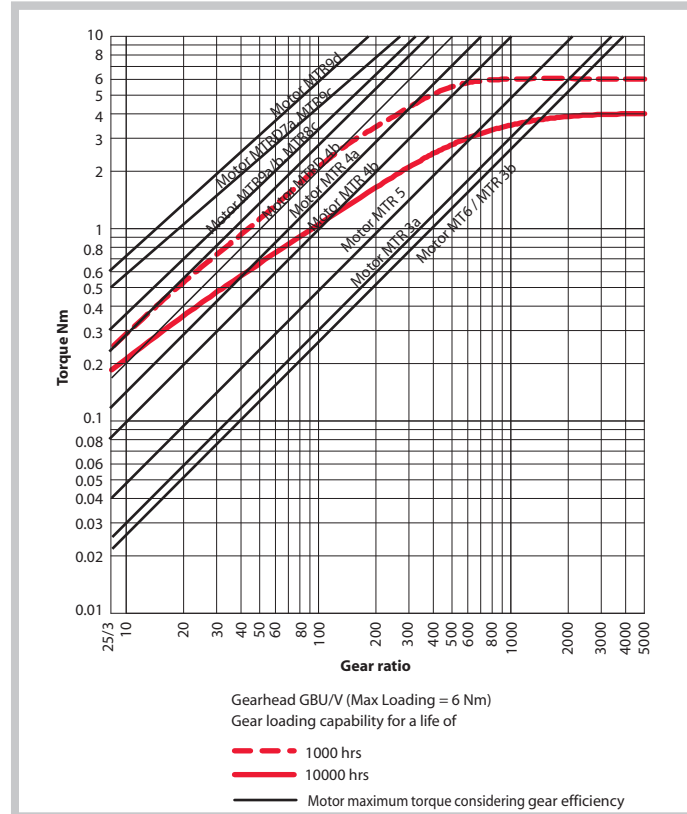

Transmission Ratios

For Transmission Ratios refer to page nos. 6 & 7.

Dimensional Drawing GBU

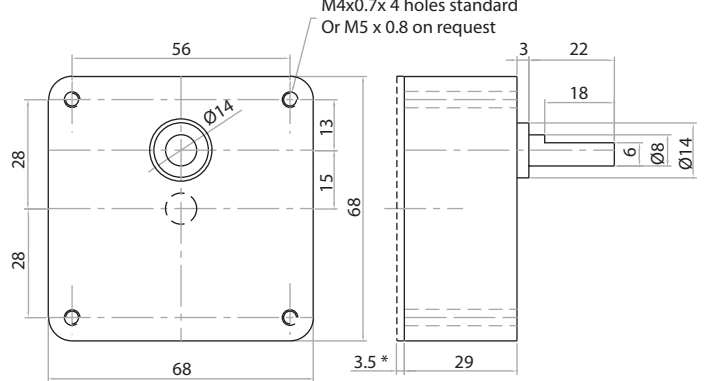

Dimensional Drawing GBV

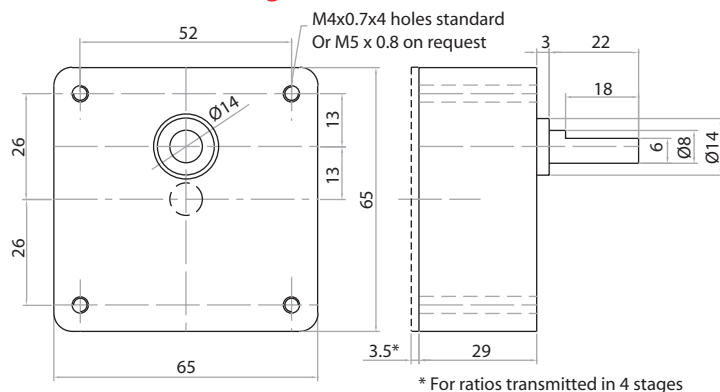

Gear Series **GBU/V**

Spur Reduction Gearhead - 6 Nm

Shaft Drawings

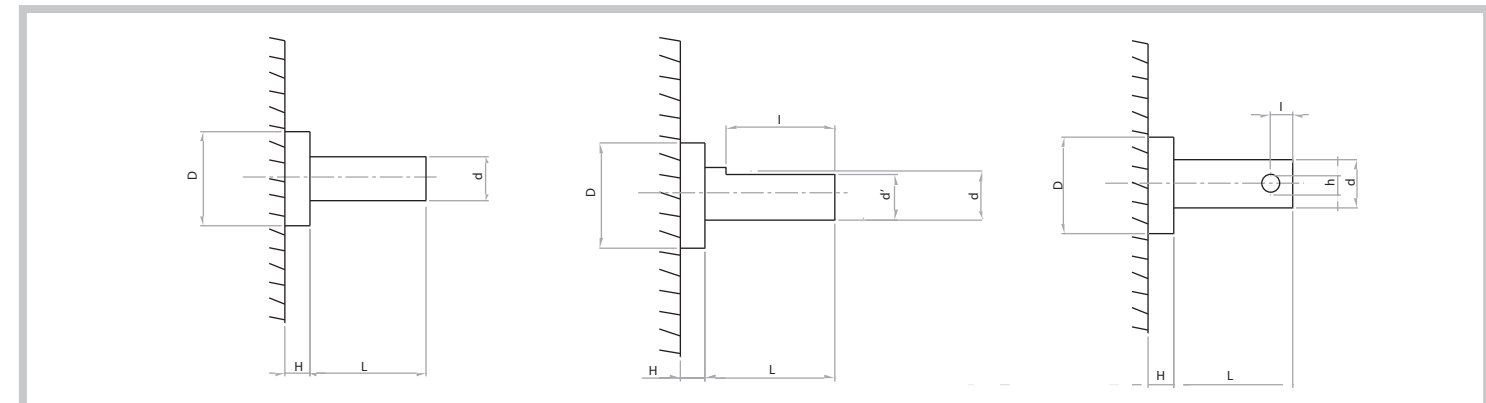

Shaft Type Catalogue

Shaft type	D	H	d (dia)	L	l	d'	h
S	14	3	8	22	18	6	
A	14	3	8	22	13		3
B	14	3	8	22			

Drawings

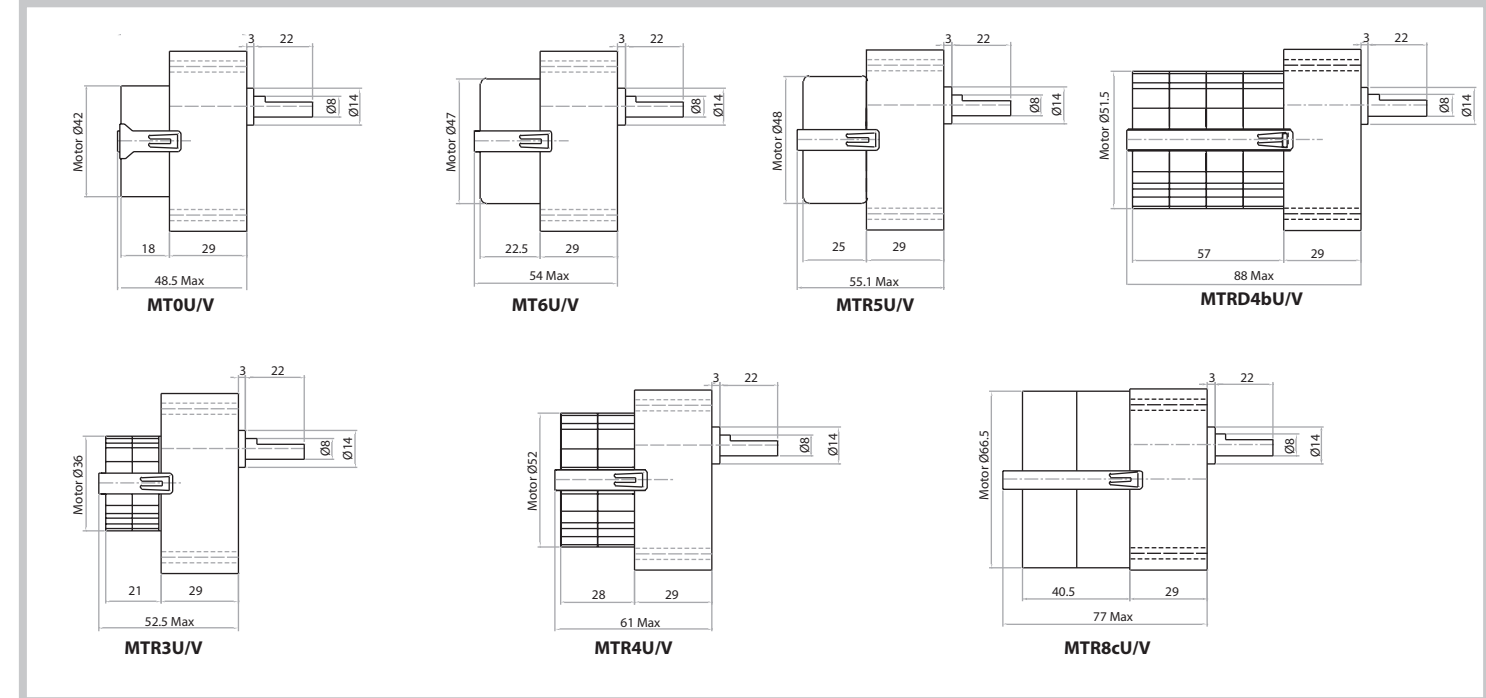

Photographs



Gear Series GB4

Spur Reduction Gearhead - 10 Nm



Design

Gearhead GB4 contains heavily loaded steel gear wheels. The spur gears rotate on fixed steel spindles which are hardened and polished to a mirror finish. The thick output shaft rotates in robust sintered bushings. It can also be mounted on a ball bearing which can be provided in the output bush of the gear box. All the gears are housed between two metal plates with a plastic frame. All bearings are permanently lubricated and therefore require no maintenance. Economical versions with poly-acetal or sintered gears available. This gear box can also be combined with small to medium sizes of DC motors.

Standard Data

Gear Type		Spur Reduction
Gear Torque	Nm	10
Combination with Mechtex motors		MT0, MT6, MTR/S3a/3b, MTR/S-5, MTR/S 4a/4b/D4b and small DC motors / (upto 40)
Mounting		any position
Weight	g	350
Axial thrust	N	100
Lateral force	N	800
Radial torque	Nm	8
Slipping clutches/free wheel		available for certain ratios
Output bearing		Sintered Bronze, Ball Bearing (on request)
Output shafts	Ø	dia. 8 x 18 mm (with a flat), others on request
Ambient temperature operation	°C	-15...+ 55
Enclosure	IP	30

Torque/Transmission Ratio/Life Graph

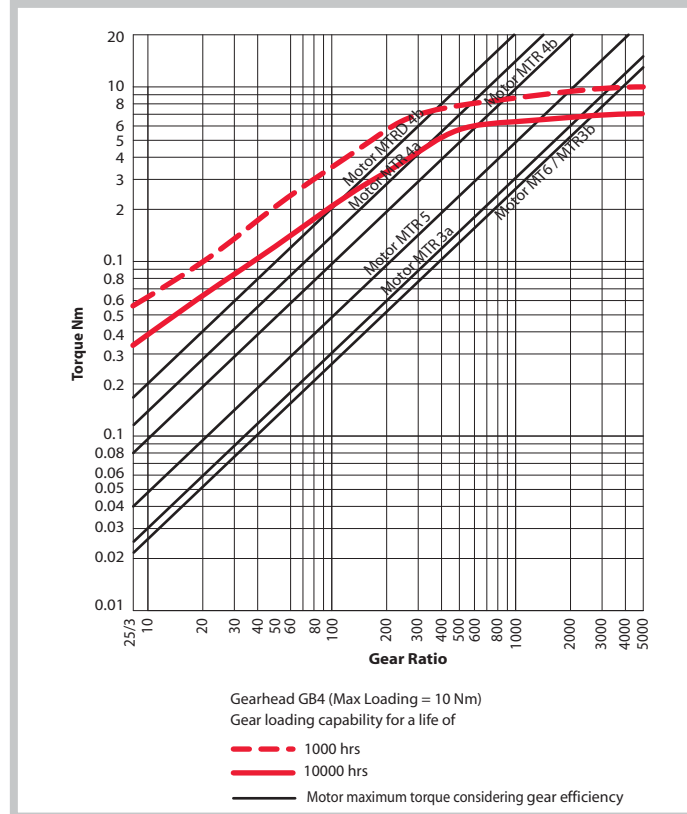

Transmission ratios

For Transmission Ratios refer to page nos. 6 & 7.

Dimensional Drawing

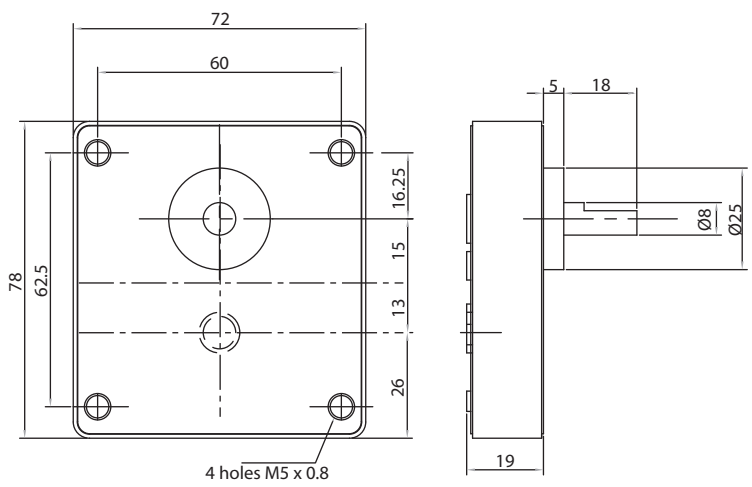

Gear Series GB4

Spur Reduction Gear head - 10 Nm

Shaft Drawings

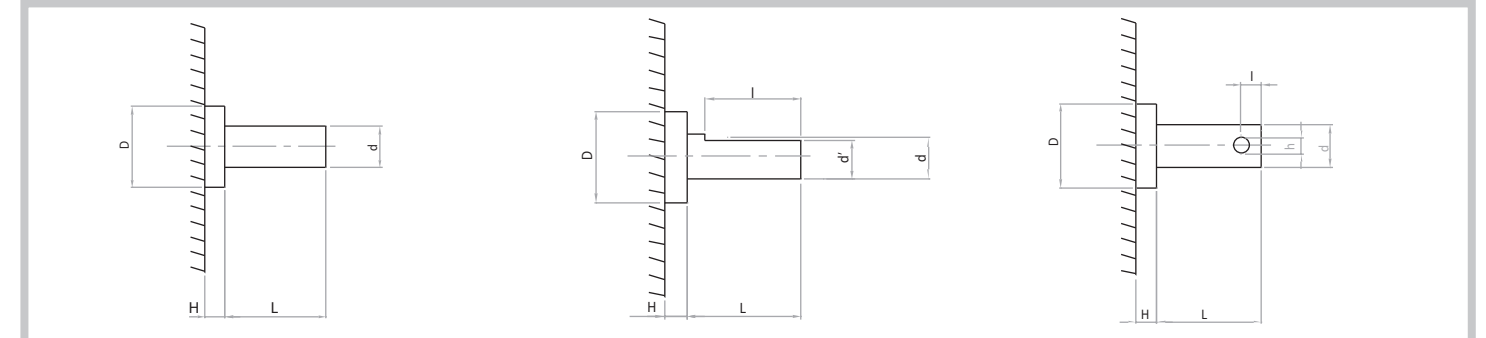

Shaft Type Catalogue

Shaft type	D	H	d(dia)	L	l	d'	h
S	25	5	8	16	8	6	
A	25	5	8	26	18	6	
C	25	5	8	17	9		3

Drawings

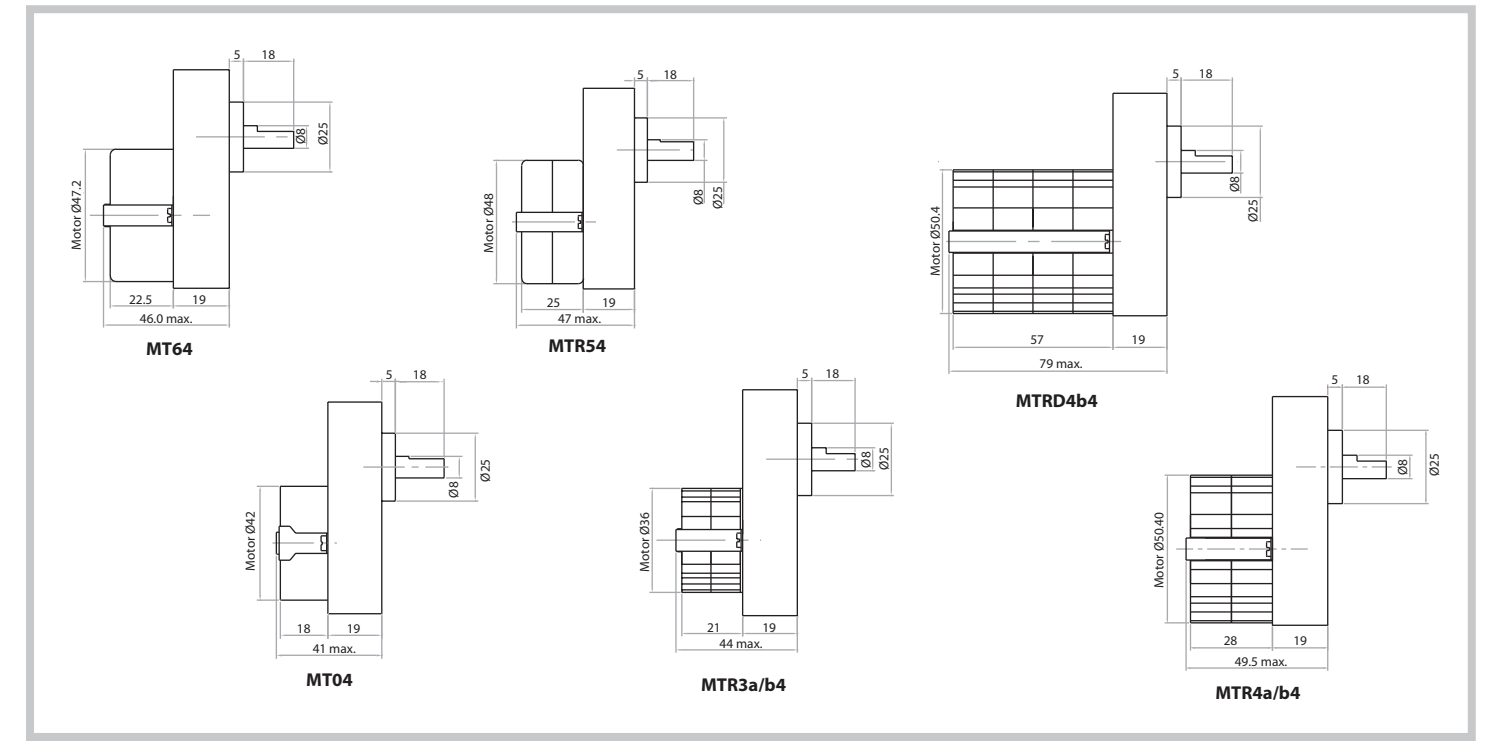

Photographs

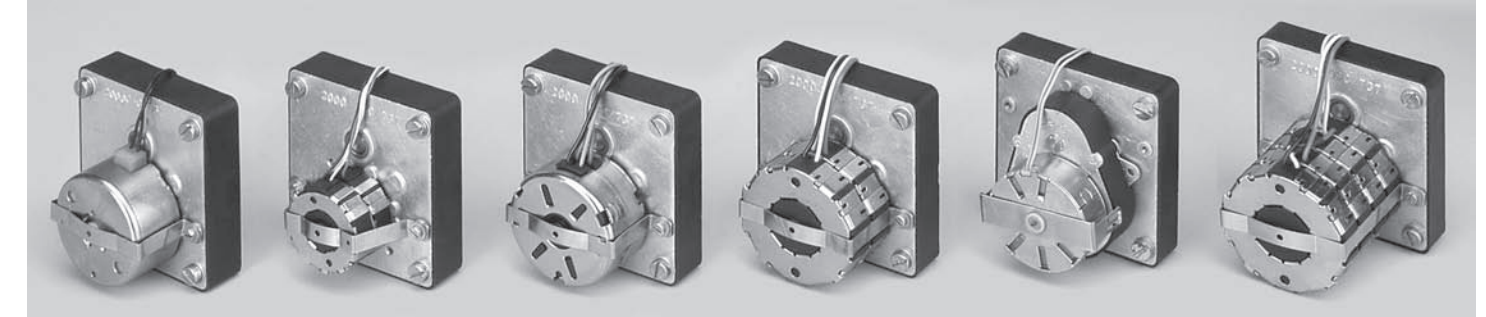

Gear Series GBW

Spur Reduction Gearhead - 15 Nm



Design

Gearhead GBW contains heavily loaded steel gear wheels. The spur gears are fixed on steel spindles which are hardened and polished to a mirror finish & rotate in sintered bushings. The thick output shaft rotates in robust sintered bushings. All the gears are housed in between metal plates & closed by plastic dust cover. All bearings are permanently lubricated and therefore require no maintenance. GBW can also be combined with small to medium sizes of DC motors (up to Ø52mm). Output shaft can also be emerging from the rear side or both sides.

Standard Data

Gear Type		Spur Reduction
Gear Torque	Nm	15
Combination with Mechtex motors		MT0,MT6,MTR/S5,MTR/S-4a/b,MTR/SD-4a/b, MTR9a/b/d, MTR/S-7a and DC motors / (upto 52)
Mounting		any position
Weight	g	550
Axial thrust	N	400
Lateral force	N	600
Radial torque	Nm	6
Output bearing		Sintered Bronze
Output shafts	Ø	dia. 12 x 19 mm (with a flat), others on request
Ambient temperature operation	°C	-15...+ 55
Enclosure	IP	30

Torque/Transmission Ratio/Life Graph

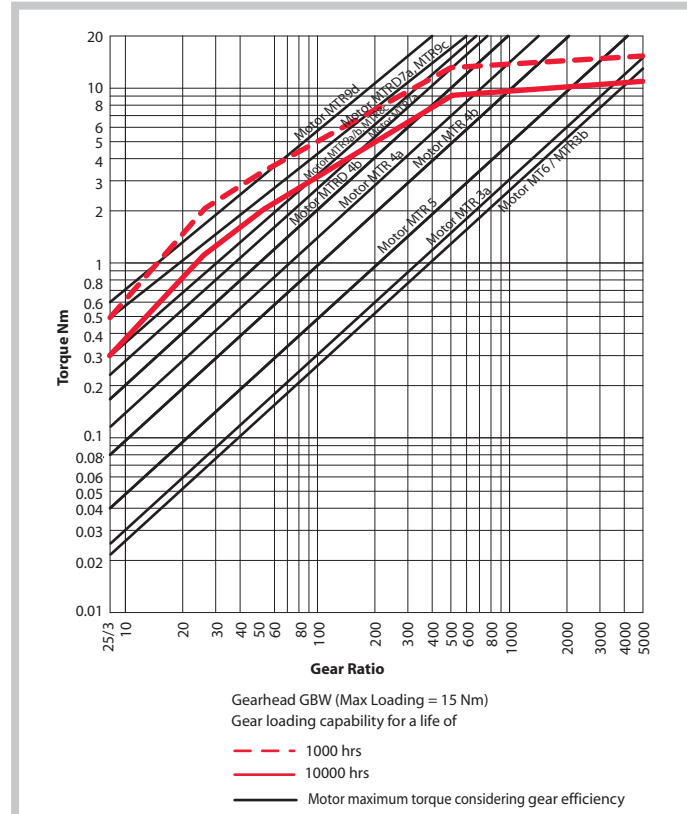

Transmission ratios

For Transmission Ratios refer to page nos. 6 & 7.

Dimensional Drawing

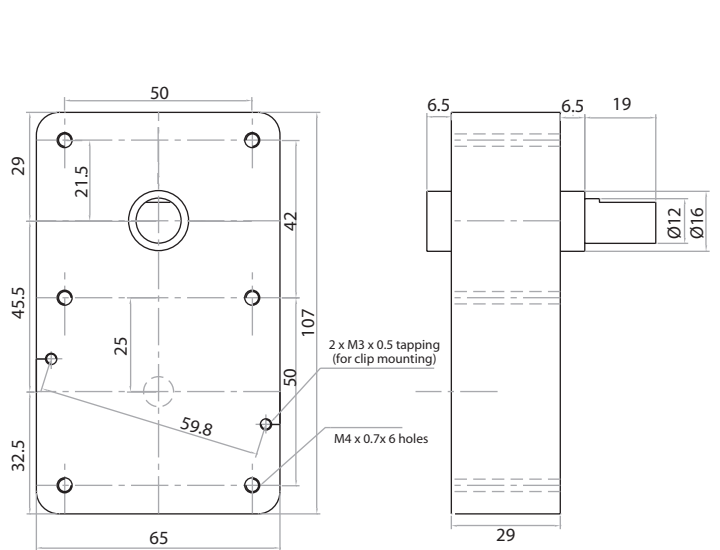

Gear Series GBW

Spur Reduction Gearhead - 15 Nm

Shaft Drawings

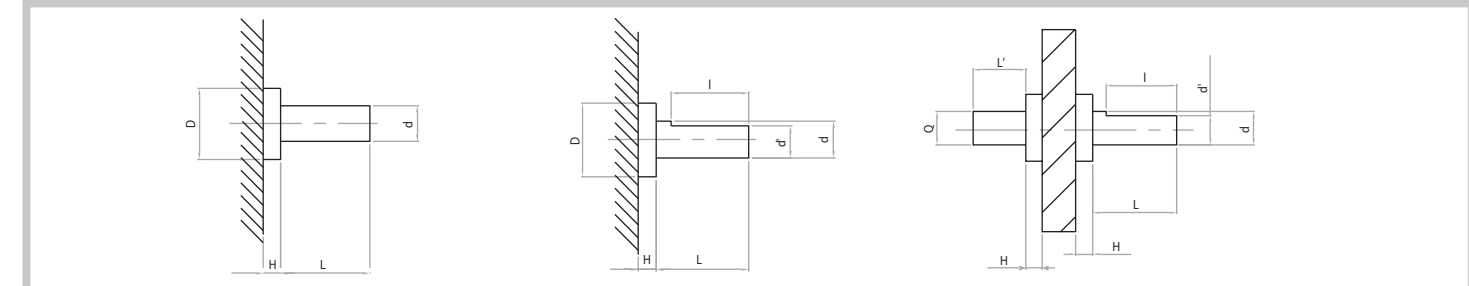

Shaft Type Catalogue

Shaft type	D	H	d (dia)	L	l	d'	L'	Q
S	16	6.5	12	19	15	11		
A	16	6.5	12	29	25	11		
B	16	6.5	12	19	15	11	17	12
C	16	6.5	12	19				
D	16	6.5	12	29				

Drawings

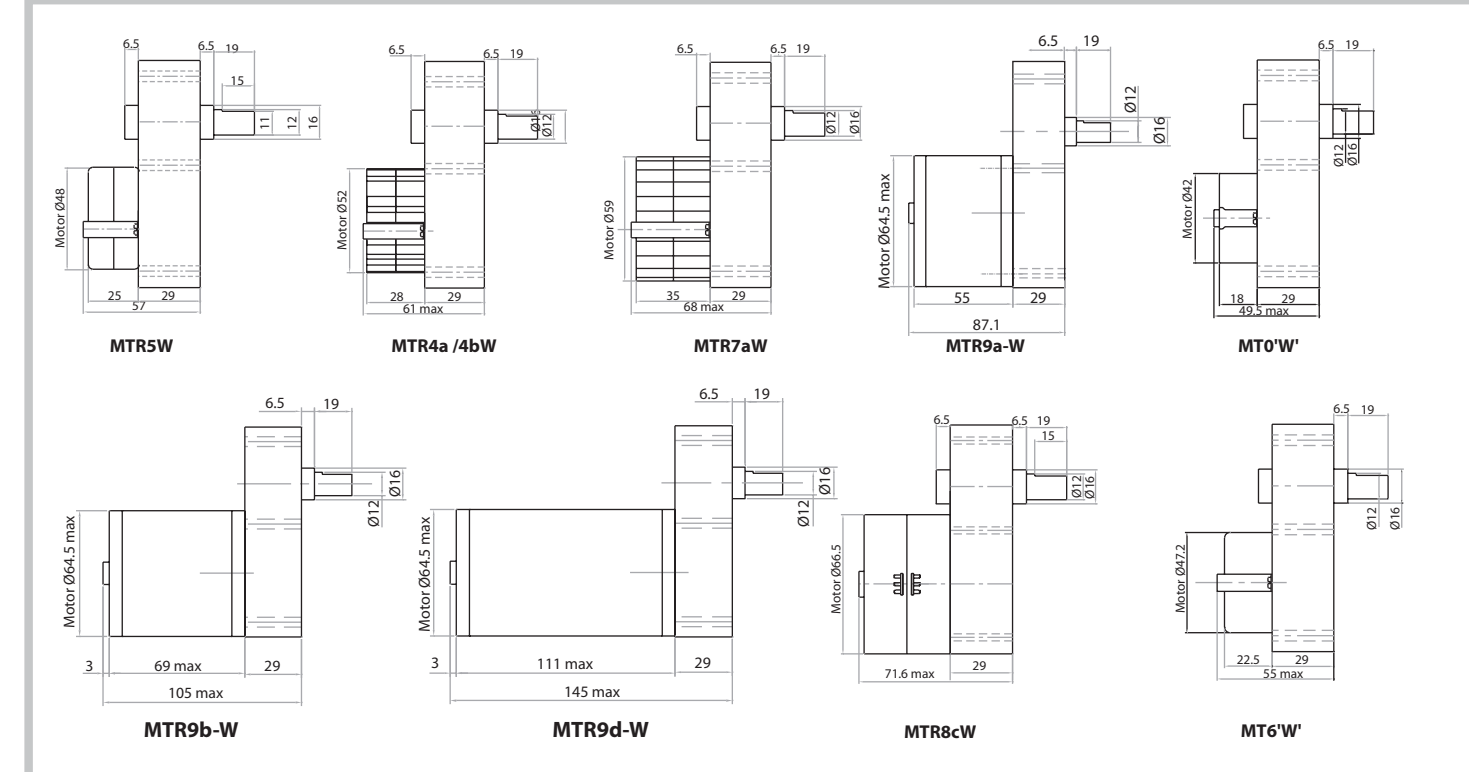

Photographs

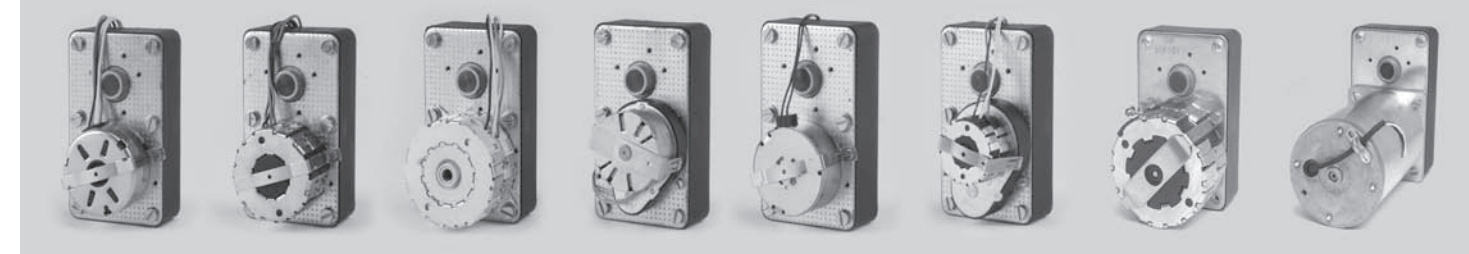

Gear Series GBX

Spur Reduction Gearhead - 30 Nm



Design

Gearhead GBX contains heavily loaded steel gear wheels. The spur gears are fixed on steel spindles which are hardened and polished to a mirror finish & rotate in sintered bushings. The thick output shaft rotates in robust bronze bushings. All the gears are housed in between metal plates & closed by plastic dust cover. All bearings are permanently lubricated and therefore require no maintenance. GBX can also be combined with small to medium sizes of DC motors (up to Ø52mm). Output shaft can also be emerging from the rear side or both sides.

Standard Data

Gear Type		Spur Reduction
Gear Torque	Nm	30
Combination with Mechtex motors		MT0, MT6, MTR/S5, MTR/S-4a/b, MTR/SD-4b, MTR/SD4b-RE & DC motors (Up to dia 52) MTR/S 7a, MTR/S 8c, MTR9a,b,d
Mounting		any position
Weight	g	850
Axial thrust	N	600
Lateral force	N	900
Radial torque	Nm	12
Output bearing		Sintered Bronze
Output shafts	Ø	dia.15 x 20 mm (with a flat), others on request
Ambient temperature operation	°C	-15...+ 55
Enclosure	IP	30

Torque/Transmission Ratio/Life Graph

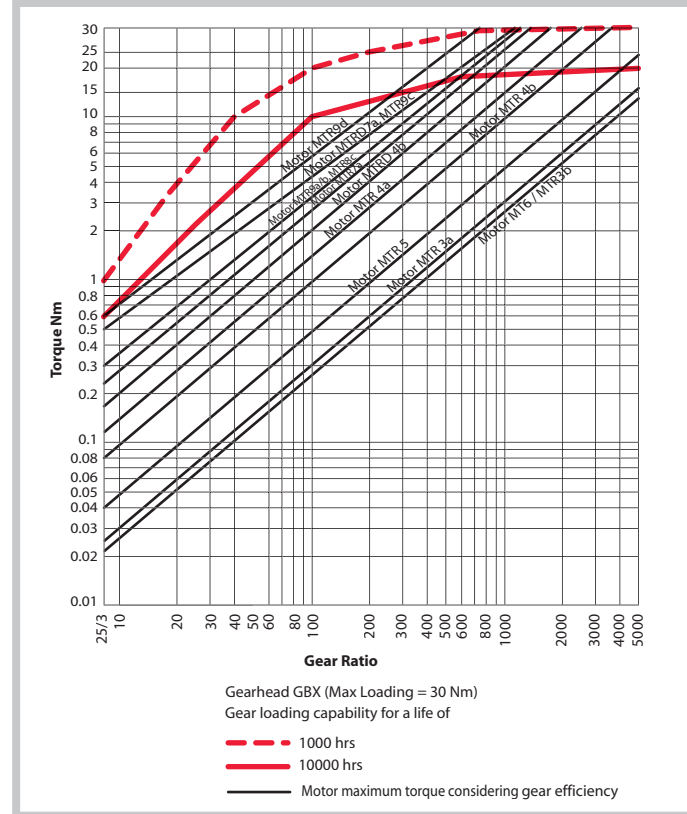

Transmission ratios

For Transmission Ratios refer to page nos. 6 & 7.

Dimensional Drawing

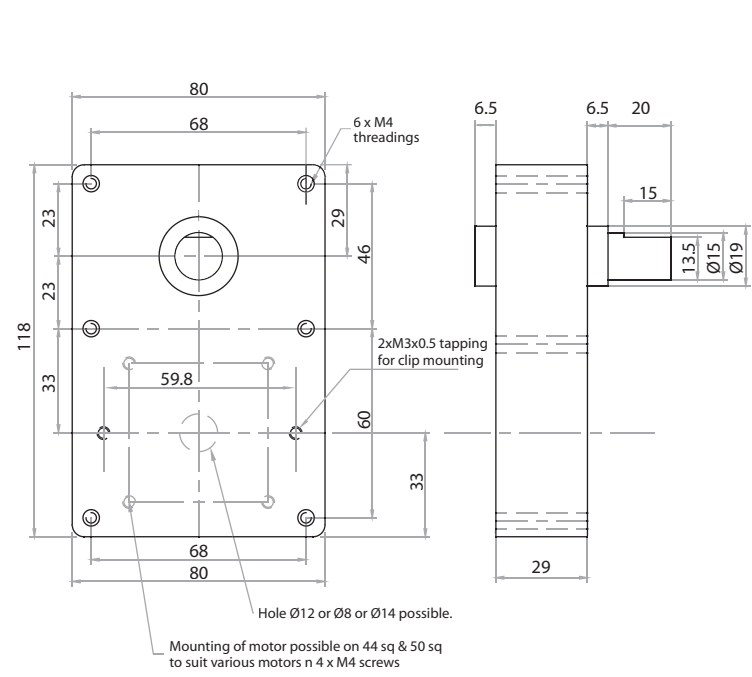

Shaft Drawings

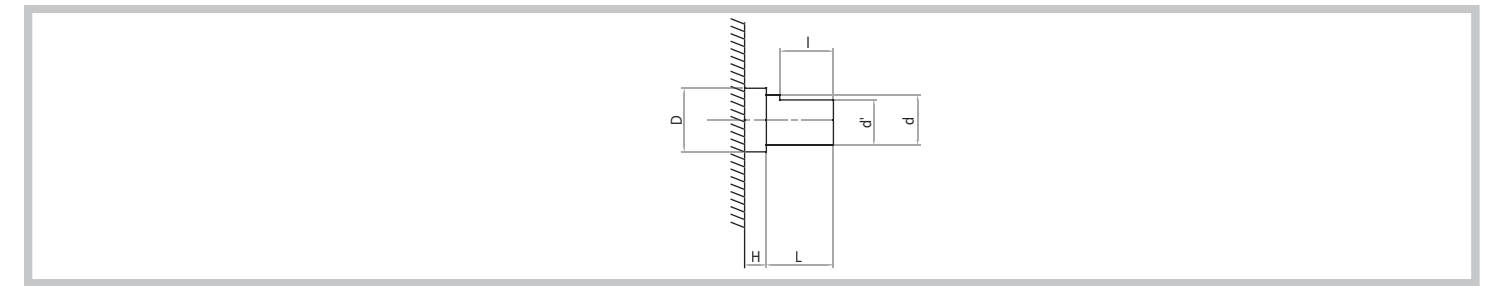

Shaft Type Catalogue

Shaft type	D	H	d (dia)	L	l	d'
S	19	6.5	15	20	15	13.5
A	19	6.5	15	40	35	13.5

Drawings

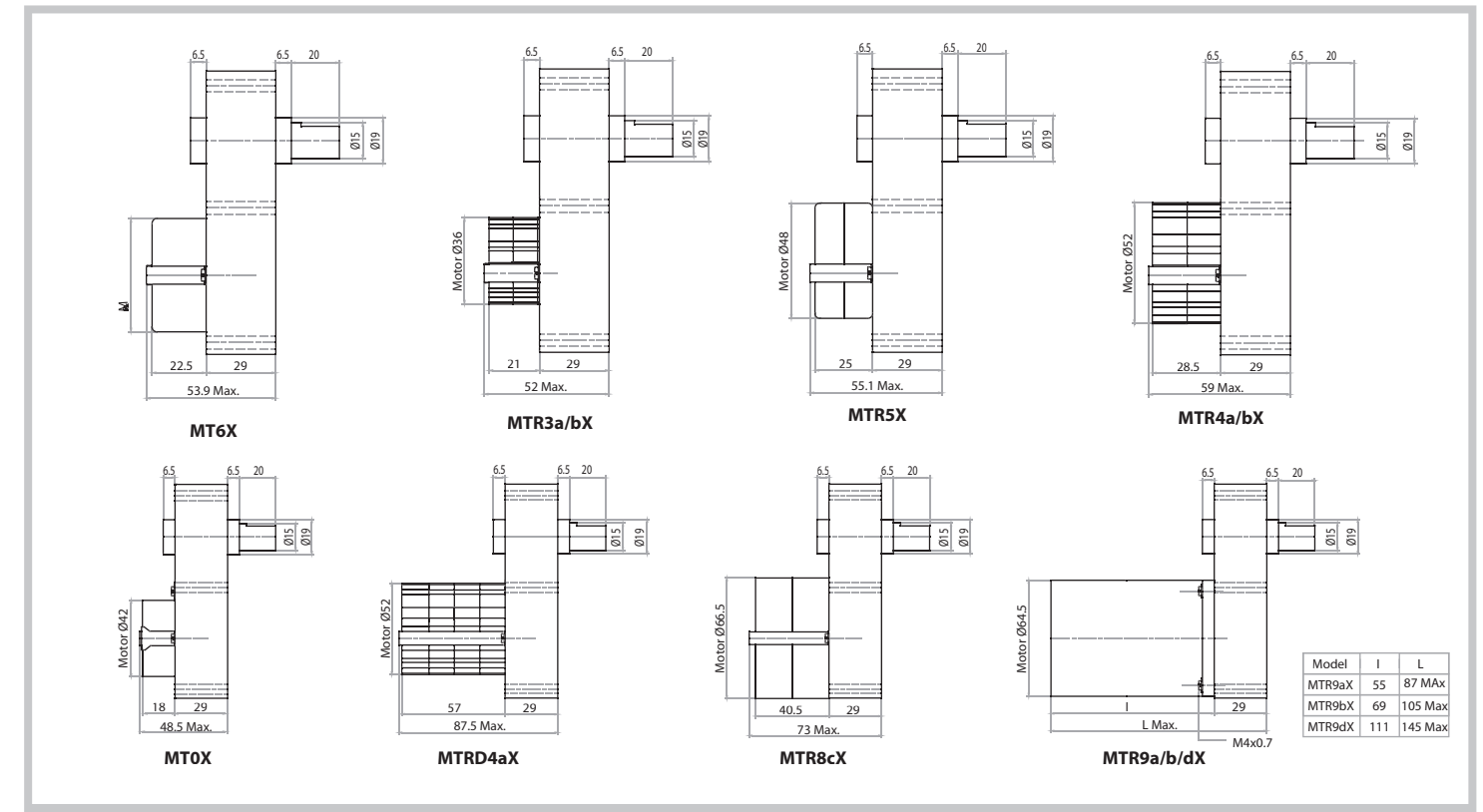

Photographs

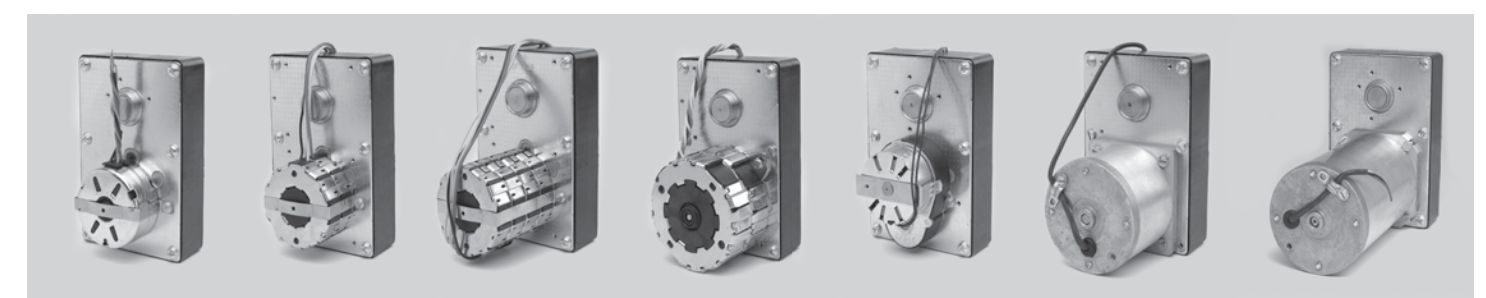

Gear Series **GBB**

Spur Reduction Gearhead - 0.5 Nm



Design

The gearhead GB B is a spur reduction gearhead with 33mm OD & OFF centre shaft meant specially for DC motors with diameters up to 33 mm. It has a possibility of 5 to 8 stage reduction with initial stages are poly-acetal gears & final stages will be steel sintered. All bearings are permanently lubricated & therefore require no maintenance. Motor is attached to gear box by means of screws. The nominal torque rating for this gearhead is 0.5 Nm with peak torque range up to 0.8 Nm. This gearhead has been categorised in 2 different housing sizes as per gear reduction for 6 to 8 stages.

Technical Data

Gear Type		Spur Reduction (1st pair helical)
Gear Torque	Nm	0.5
Combination with Mechtex motors		DC24 / DC28 / D32 / DC30* others on request
Mounting		any position ; preferably with shaft horizontal
Weight	g	Variable with reduction stages (140 approx)
Axial thrust	N	15
Lateral force	N	50
Radial torque	Nm	0.6
Output bearing		Sintered Bronze
Output shafts	Ø	dia.5 x 12 mm (with a flat)
Ambient temperature operation	°C	-15...+ 55
Enclosure	IP	30

Transmission Ratios

GB-2 - 72.92*, 125, 182.3*, 312.5

GB-3 - 455.73*, 781.25, 1139.32*, 1953.125

* Possible to mount DC30 motor with these ratios only.

Dimensional Drawing

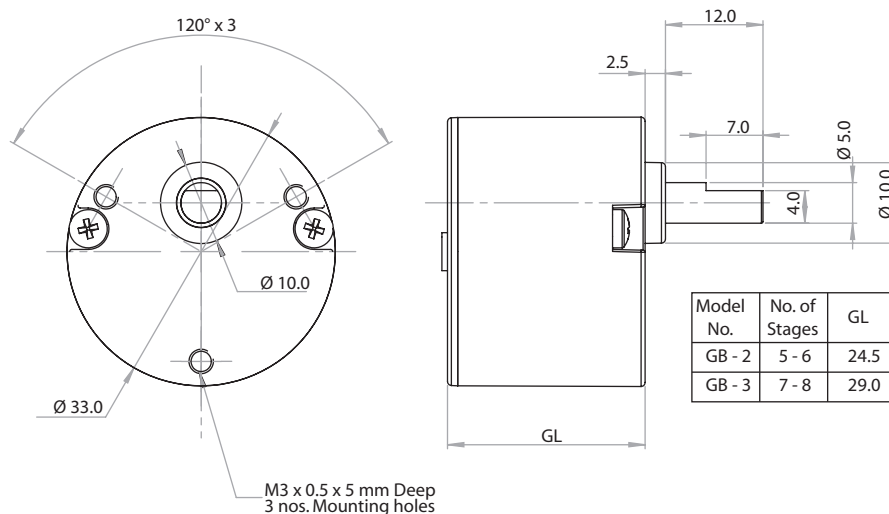

Photographs



Gear Series **GBC**

Spur Reduction Gearhead - 0.5 Nm

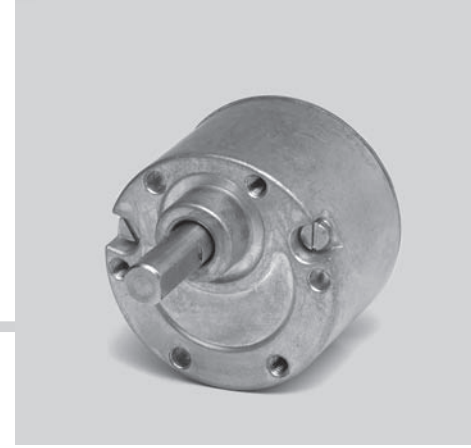

Design

The gearhead GB C is a spur reduction gearhead with 37mm OD & OFF centre shaft meant specially for DC motor with diameters up to 36 mm. It has a possibility of 2 to 8 stage reduction with initial stages are poly-acetal gears & final stages will be steel sintered .All bearings are permanently lubricated & therefore require no maintenance. Motor is attached to gear box by means of screws. The nominal torque rating for this gearhead is 0.5 Nm with peak torque range up to 0.8 Nm. This gearhead has been categorised in 3 different housing sizes as per gear reduction for 4 , 6 & 8 stages.

Technical Data

Gear Type		Spur Reduction(1st pair helical)
Gear Torque	Nm	0.5
Combination with Mechtex motors		DC24 / DC28 / D32 / DC30* / DC38* others on request
Mounting		any position ; preferably with shaft horizontal
Weight	g	Variable with reduction stages (180 approx)
Axial thrust	N	15
Lateral force	N	50
Radial torque	Nm	0.6
Output bearing		Sintered Bronze
Output shafts	Ø	dia.6 x 15.3 mm (with a flat)
Ambient temperature operation	°C	-15...+ 55
Enclosure	IP	30

Transmission Ratios

GC-1 - 5.54*, 9.5, 13.85*, 23.75, 34.64*, 59.38

GC-2 - 86.59*, 148.38, 216.47*, 371.1

GC-3 - 541*, 927.7, 1352.95*, 2319

* Possible to mount DC30 / DC38 motors with these ratios only.

Dimensional Drawing

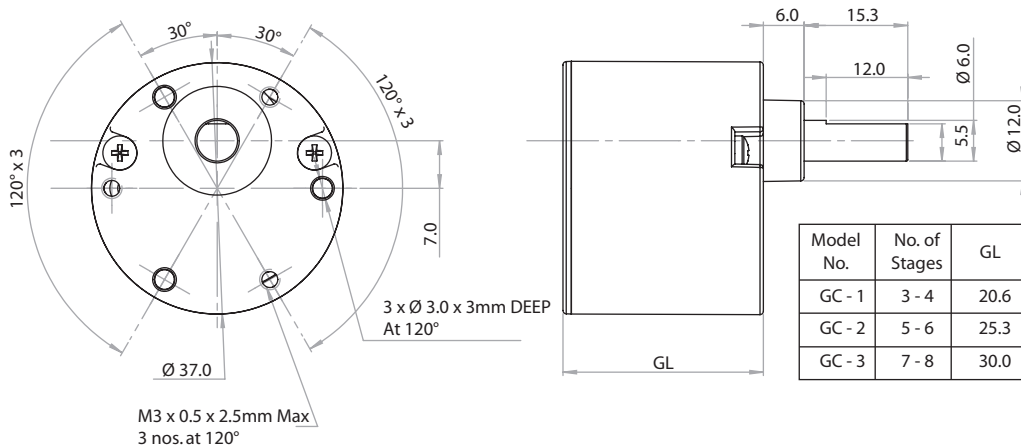

Photographs



DC28 Combinations

DC Geared Motors

Design

DC28 Series motors are DC motors (Outsourced) that are used in combination with many Mechtex gearheads. Depending on the application, output speed, load applied etc the type of gearhead can be selected. Various types of gears i.e poly acetal, sintered iron, brass, SRBF (helical) & steel gears can be used based on the load considerations. Poly acetal or sintered gears usually are used for noise dampening & complete poly acetal gears are used when the output torque required is less. All bearings are permanently lubricated and therefore require no maintenance.

Ordering Data (e.g.)

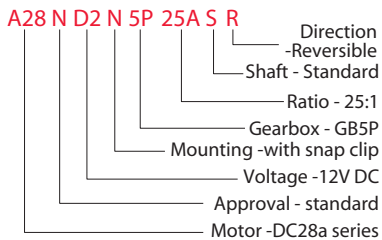

Standard Data

Motor Type		PM Brushed dc motor
Combination with Mechtex Gear Series		GB 2/5P/5H, GB 380CP, GB B/C, GB 3/4/7/8, GB V/U/W/X
Standard motor voltages	V	24, 12, 6 & 3
Weight	g	65
Enclosure	IP	30
Mounting		By snap clip or by screws
Life expectancy		Approx 500 hours @ max efficiency
Direction		Reversible

Technical Data

Mechtex MODEL No.	Physical data Dim. mm	No Load data			Data at max efficiency					Stall		
		Voltage V DC	Speed RPM	No load Current A	Speed RPM	Current Amps	Torgue Ncm	Effic. (%)	Power W(out)	Power W(in)	Torgue Ncm	Current mA
A28	27.5 x 32.5	24	5000	0.040	3945	0.099	0.280	55	1.170	2.109	1.360	350.000
A28	27.5 x 32.5	12	2500	0.035	1577	0.077	0.210	40	0.343	0.853	0.610	171.000
A28	27.5 x 32.5	6	1200	0.032	630	0.051	0.090	23	0.059	0.253	0.250	85.000
B28	27.5 x 32.5	12	4800	0.080	3563	0.224	0.350	49	1.296	2.633	2.960	1330.000
B28	27.5 x 32.5	6	2400	0.070	1537	0.143	0.190	38	0.311	0.825	0.730	364.000
B28	27.5 x 32.5	3	1200	0.070	577	0.105	0.120	25	0.070	0.285	0.280	176.000
L28	28 x 46.6	24	3000	0.035	2431	0.134	0.78	62	1.949	3.135	4.010	572.000
L28	28 x 46.6	12	1500	0.035	1118	0.090	0.48	55	0.555	1.010	2.000	287.000
L28	28 x 46.6	6	700	0.028	553	0.051	0.20	45	0.112	0.253	0.920	149.000
Q28	27.5 x 46.5	24	6000	0.070	5076	0.315	1.01	71	5.312	7.470	6.600	1745.000
Q28	27.5 x 46.5	12	3000	0.070	2376	0.230	0.62	57	1.516	2.670	3.190	930.000
Q28	27.5 x 46.5	6	1500	0.060	1174	0.130	0.30	52	0.364	0.699	1.500	459.000
W28	28.0 x 38.0	24	7500	0.100	6410	0.368	0.880	70	5.791	8.311	5.600	1924
W28	28.0 x 38.0	12	3700	0.090	3000	0.259	0.590	63	1.808	2.883	3.040	1059
W28	28.0 x 38.0	6	1800	0.075	1387	0.169	0.310	51	0.449	0.884	1.460	542.000

Assembly Drawings

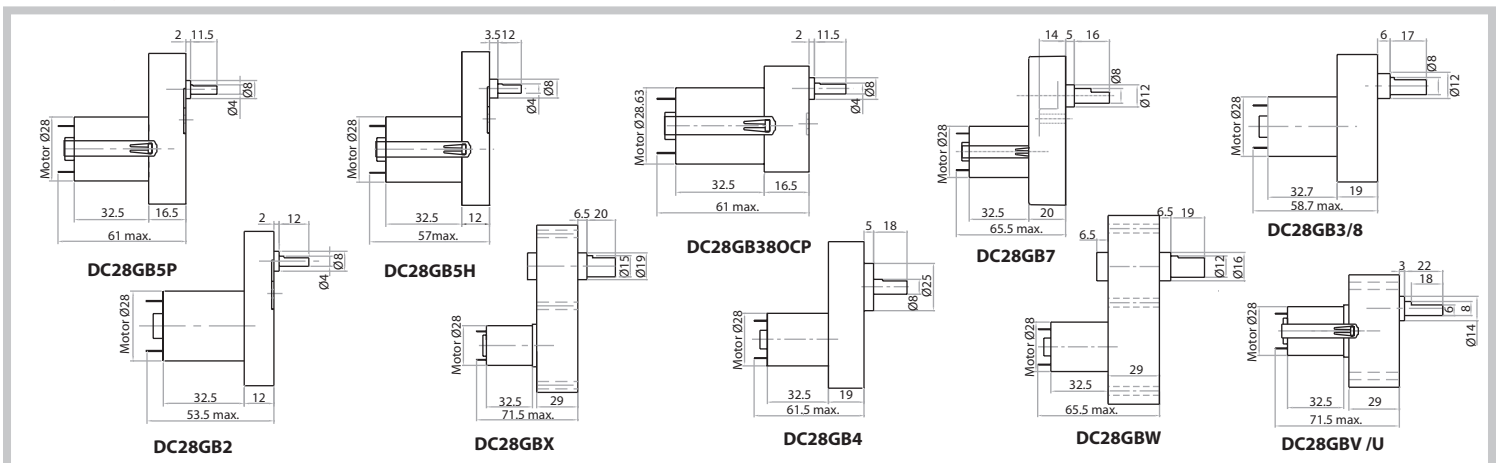

Photographs



DC30 Combinations

DC Geared Motors

Design

DC30 Series motors are DC motors (Outsourced) that are used in combination with many Mechtex gearheads. Depending on the application, output speed, load applied etc the type of gearhead can be selected. Various types of gears i.e poly acetal, sintered iron, brass, SRBF (helical) & steel gears can be used based on the load considerations. Poly acetal or sintered gears usually are used for noise dampening & complete poly acetal gears are used when the output torque required is less. All bearings are permanently lubricated and therefore require no maintenance.

Ordering Data (e.g.)

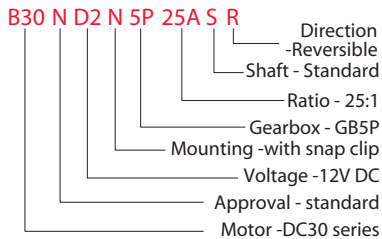

Standard Data

Motor Type		PM Brushed dc motor
Combination with Mechtex Gear Series		GB 2/5P/5H, GB 380CP, GB B/C, GB 3/4/7/8, GB V/U/W/X
Standard motor voltages	V	24, 12, 6 & 3
Weight	g	75
Enclosure	IP	30
Mounting		By snap clip or by screws
Life expectancy		Approx 500 hours @ max efficiency
Direction		Reversible

Technical Data

Mechtex MODEL No.	Physical data Dim. mm Dai. height	No Load data			Data at max efficiency						Stall	
		Voltage V DC	Speed RPM	No-load Current A	Speed RPM	Current Amps	Torgue Ncm	Effic. (%)	Power W(out)	Power W(in)	Torgue Ncm	Current mA
A30	32.5 X 29	24	6200	0.060	5000	0.210	0.620	62.31	5.040	3.170	3.200	31.370
A30	32.5 X 29	12	3100	0.045	2345	0.146	0.350	49	0.847	1.713	1.420	465.000
A30	32.5 X 29	6	1500	0.035	1100	0.090	0.160	36	0.183	0.508	0.660	237.000
B30	32.5 X 29	12	6200	0.120	4990	0.438	0.560	55	2.866	5.254	3.070	1900.000
B30	32.5 X 29	6	3100	0.100	2216	0.294	0.390	51	0.892	1.734	1.710	1041.000
B30	32.5 X 29	3	1500	0.090	980	0.195	0.230	41	0.229	0.560	0.820	533.000
M30	32.5 X 29	24	2500	0.025	1752	0.070	0.39	45	0.705	1.578	1.460	188.000
M30	32.5 X 29	12	1200	0.020	704	0.049	0.22	32	0.163	0.505	0.680	96.000

Assembly Drawings

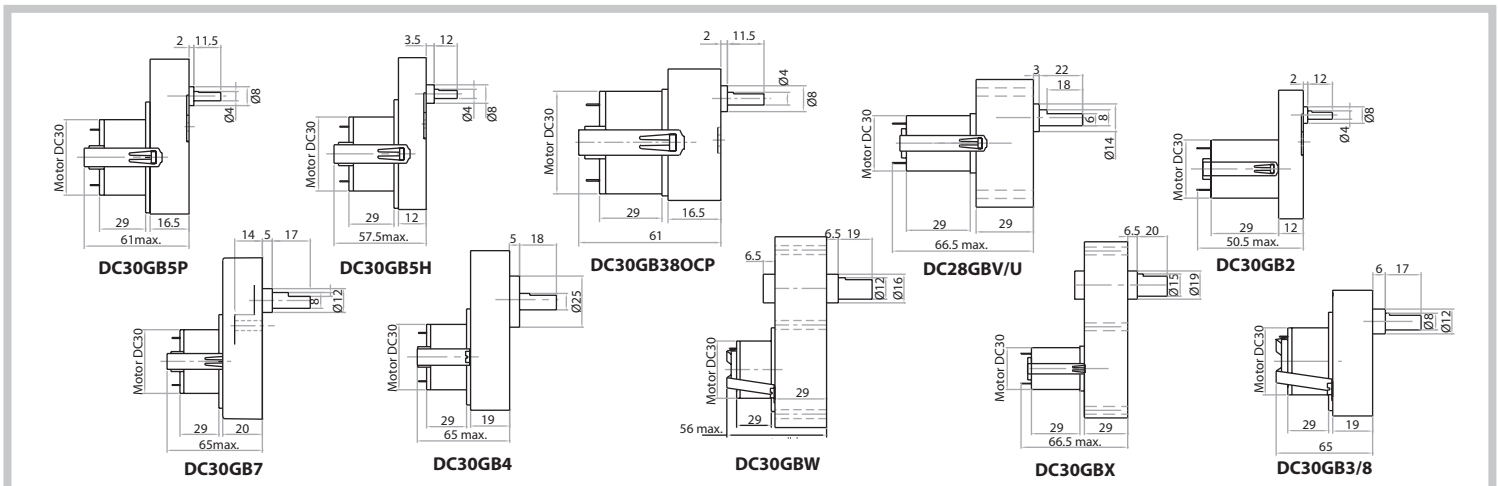

Photographs



DC32 Combinations

DC Geared Motors

Design

DC32 Series motors are DC motors (Outsourced) that are used in combination with many Mechtex gearheads. Depending on the application, output speed, load applied etc the type of gearhead can be selected. Various types of gears i.e poly acetal, sintered iron, brass, SRBF (helical) & steel gears can be used based on the load considerations. Poly acetal or sintered gears usually are used for noise dampening & complete poly acetal gears are used when the output torque required is less. All bearings are permanently lubricated and therefore require no maintenance.

Ordering Data (e.g.)

B32 N D2 N 5H 50A S R

- Motor -DC32 series
- Approval - standard
- Voltage -12V DC
- Mounting -with snap clip
- Gearbox - GB5H
- Ratio - 50:1
- Shaft - Standard
- Reversible
- Direction

Standard Data

Motor Type		PM Brushed dc motor
Combination with Mechtex Gear Series		GB 2/5P/5H, GB 38OCP, GB B/C, GB 3/4/7/8, GB V/U/W/X
Standard motor voltages	V	24, 12, 6 & 3
Weight	g	40
Enclosure	IP	30
Mounting		By snap clip or by screws
Life expectancy		Approx 500 hours @ max efficiency
Direction		Reversible

Technical Data

Mechtex MODEL No.	Physical data Dim. mm Dai. height	No Load data			Data at max efficiency						Stall	
		Voltage V DC	Speed RPM	No-load Current A	Speed RPM	Current Amps	Torgue Ncm	Effic. (%)	Power W(out)	Power W(in)	Torgue Ncm	Current mA
A32	32 X 19.5	24	6000	0.025	4740	0.075	0.200	54	0.966	1.791	0.990	305.000
A32	32 X 19.5	12	3000	0.015	2319	0.045	0.110	50	0.266	0.529	0.530	164.000
A32	32 X 19.5	6	1500	0.012	1055	0.032	0.070	42	0.076	0.179	0.260	86.000
B32	32 X 19.5	12	5400	0.035	4653	0.111	0.180	67	0.883	1.318	1.200	604.000
B32	32 X 19.5	6	2700	0.030	2273	0.074	0.110	62	0.256	0.412	0.640	337.000
B32	32 X 19.5	3	1350	0.030	1086	0.047	0.060	60	0.070	0.116	0.330	175.000

Assembly Drawings

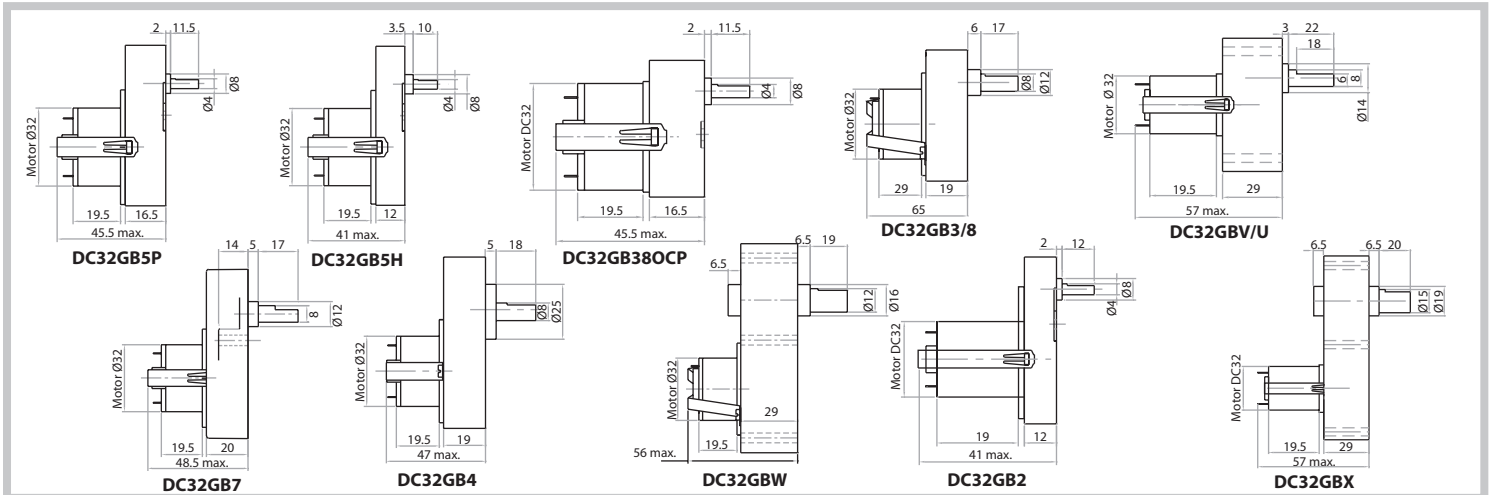

Photographs



DC38 Combinations

DC Geared Motors

Design

DC38 Series motors are DC motors (Outsourced) that are used in combination with many Mechtex gearheads. Depending on the application, output speed, load applied etc the type of gearhead can be selected. Various types of gears i.e poly acetal, sintered iron, brass, SRBF (helical) & steel gears can be used based on the load considerations. Poly acetal or sintered gears usually are used for noise dampening & complete poly acetal gears are used when the output torque required is less. All bearings are permanently lubricated and therefore require no maintenance.

Ordering Data (e.g.)

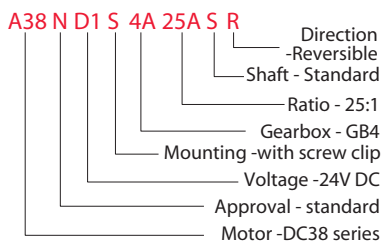

Standard Data

Motor Type		PM Brushed dc motor
Combination with Mechtex Gear Series		GB 2/5P/5H, GB 38OCP, GB B/C, GB 3/4/7/8, GB V/U/W/X
Standard motor voltages	V	24, 12, 6 & 3
Weight	g	220
Enclosure	IP	20
Mounting		By screws
Life expectancy		Approx 500 hours @ max efficiency
Direction		Reversible

Technical Data

Mecthex MODEL No.	Physical data Dim. mm Dai. height	No Load data			Data at max efficiency						Stall	
		Voltage V DC	Speed RPM	No-load Current A	Speed RPM	Current Amps	Torgue Ncm	Effic. (%)	Power W(out)	Power W(in)	Torgue Ncm	Current mA
A38	36.3 X 50.1	24	5000	0.090	4184	0.480	1.780	69	7.661	11.103	12.700	2860.000
A38	36.3 X 50.1	12	2500	0.080	1998	0.308	1.060	62	2.183	3.543	6.290	1437.000
A38	36.3 X 50.1	6	1200	0.080	821	0.216	0.650	45	0.549	1.208	2.480	593.000
B38	36 X 50.1	12	5000	0.200	3747	0.867	1.550	59	5.995	10.186	7.840	3490.000
B38	36 X 50.1	6	2500	0.180	1845	0.426	0.680	54	1.287	2.367	3.550	1664.000
B38	36 X 50.1	3	1200	0.160	745	0.314	0.430	42	0.339	0.803	1.580	794.000
M38	36.0 X 50.1	24	2800	0.080	2198	0.186	1.070	55	2.418	4.377	4.610	642.000
M38	36.0 X 50.1	12	1350	0.070	890	0.139	0.660	38	0.606	1.599	2.100	315.000
M38	36.0 X 50.1	6	580	0.065	382	0.086	0.290	25	0.117	0.463	0.900	156.000

Assembly Drawings

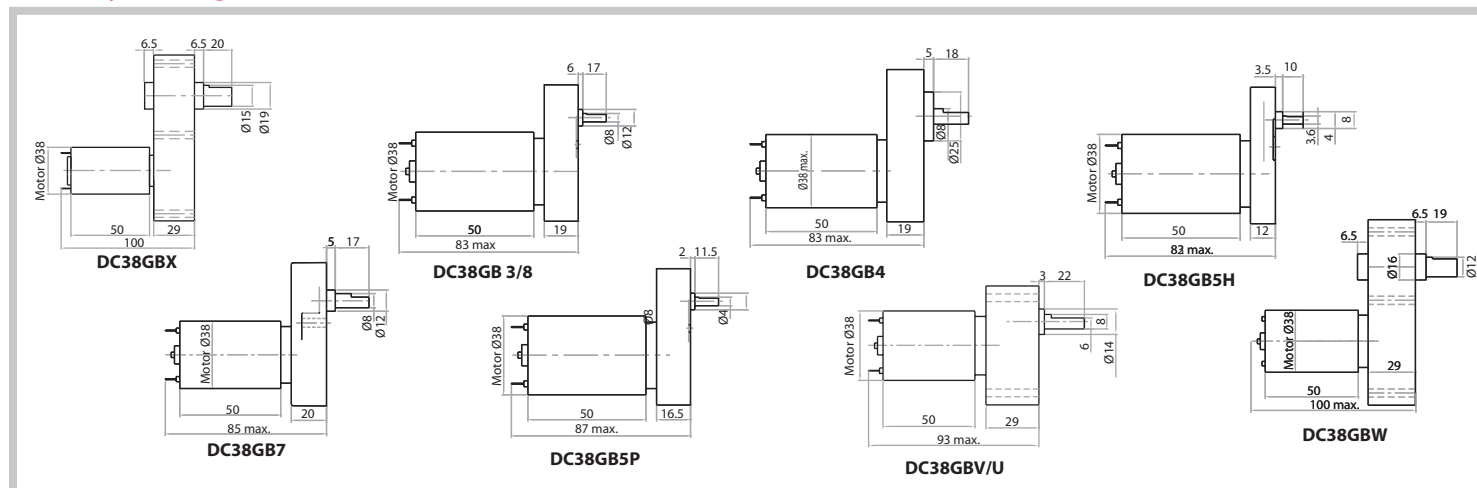

Photographs



DC42/DC52 Combinations

DC Geared Motors

Design

DC42/ DC52 Series motors are DC motors (Outsourced) that are used in combination with some Mechtex gearheads. Depending on the application, output speed, load applied etc the type of gearhead can be selected. Case hardened steel gears are used due to the high torque generated by these motors. First pair of gears can be helical to damp the noise. All bearings are permanently lubricated and therefore require no maintenance.

Ordering Data (e.g.)

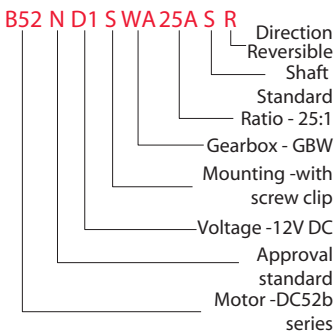

Standard Data

Motor Type		PM Brushed dc motor
Combination with Mechtex Gear Series		GB V/U, GB W/X Only
Standard motor voltages	V	24, 12, 6 & 3
Weight (DC42/DC52)	g	360/480
Enclosure	IP	20
Mounting		By screws
Life expectancy		Approx 500 hours @ max efficiency
Direction		Reversible

Technical Data

Mecthex MODEL No.	Physical data Dim. mm Dai. height	No Load data			Data at max efficiency						Stall	
		Voltage V DC	Speed RPM	No-load Current A	Speed RPM	Current Amps	Torgue Ncm	Effic. (%)	Power W(out)	Power W(in)	Torgue Ncm	Current mA
A42	42.2 x 66	24	5050	0.400	4120	1.362	5.69	74	24.075	32.645	40.200	8940.000
A42	42.2 x 66	12	2500	0.300	2021	0.951	3.48	63	7.223	11.486	21.690	4917.000
A42	42.2 x 66	6	1200	0.280	932	0.667	2.21	53	2.095	3.984	10.830	2538.000
B42	42.2 x 66	12	5000	0.700	4421	3.576	6.640	70	30.147	42.986	43.270	19897.000
B42	42.2 x 66	6	2500	0.620	2123	2.041	3.46	62	7.544	12.215	22.790	10666.000
B42	42.2 x 66	3	1250	0.580	922	1.648	2.58	51	2.443	4.819	11.120	5442.000
M42	42.4 x 66	24	2700	0.210	2312	0.508	3.01	60	7.147	11.994	16.810	2279.000
M42	42.4 x 66	12	1350	0.160	1096	0.318	1.84	56	2.071	3.725	8.640	1159.000
M42	42.4 x 66	6	650	0.130	472	0.218	1.10	43	0.533	1.242	3.950	574.000
A52	52.5 x 69	24	5000	0.500	4195	2.563	9.240	65	39.807	61.323	59.840	14318.000
A52	52.5 x 69	12	2500	0.400	1970	1.569	5.48	59	11.087	18.809	30.070	7090.000
A52	52.5 x 69	6	1250	0.350	902	0.993	3.02	48	2.797	5.875	13.070	3320.000
B52	52.5 x 69	12	5050	0.900	4325	3.916	7.110	67	31.580	47.086	54.000	24900.000
B52	52.5 x 69	6	2500	0.900	1881	2.864	4.850	54	9.369	17.229	24.700	11472.000
B52	52.5 x 69	3	1200	0.850	810	2.170	3.350	43	2.787	6.485	12.150	5961.000
M52	52.0 x 69	24	2700	0.280	2193	0.788	5.1	63	11.553	18.422	29.5	3619
M52	52.0 x 69	12	1300	0.250	1037	0.505	2.8	51	2.961	5.804	14.2	1889
M52	52.0 x 69	6	600	0.250	434	0.364	1.7	39	0.753	1.935	6.6	941

Assembly Drawings

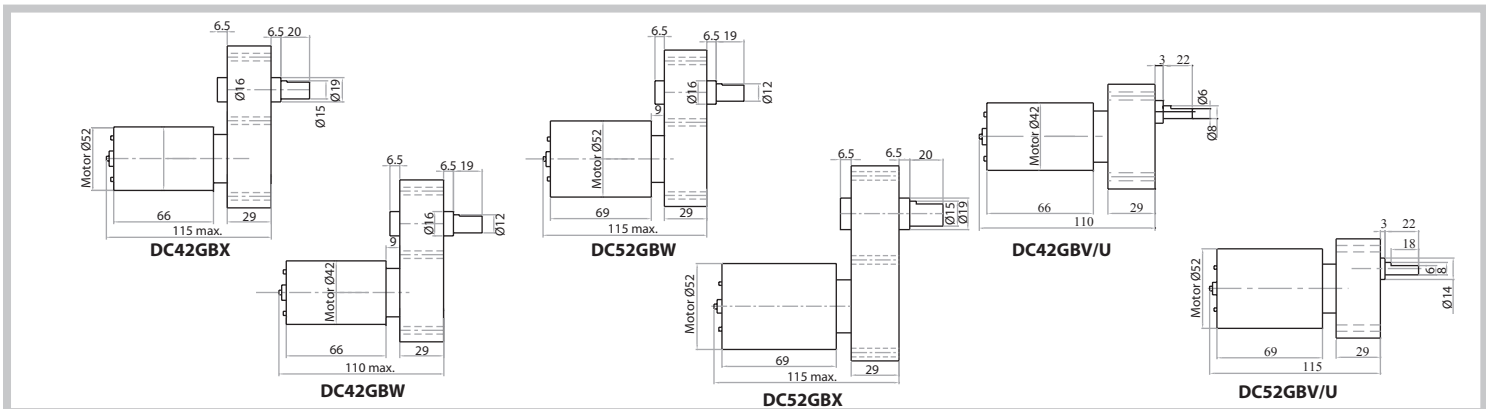

Photographs



List of Distributors

Austria

Elra Antriebstechnik Vertriebs Ges m.b.H
Tel: +43 1 21417850
Email: r.schloeglhofer@elra.at

Australia

Ingrams Time Systems Pty Ltd.
Tel: (03) 9876 0066
Email: sales@ingrams.com.au

Belgium and Luxembourg

BOHEZ Concept & Support BVBA
Tel: +32 9 344 89 98
Email: jf@bohez.com

Denmark

Ara-El Aps
Tel: + 45 56 28 65 50
Email: pn@ara-el.dk

France

Mechtex Italy SRL
Tel: 0543-704597
Email : o.corsini@mechtex.com

Germany

Powertronic Drive Systems GmbH
Tel: +49 30 771 9635
Email: info@power-tronic.com

Italy

Mechtex Italy SRL
Tel: 0543-704597
Email : o.corsini@mechtex.com.

Netherlands

Zilvertron
Tel: +31 (0)18 23 05 045
Email: j.korevaar@zilvertron.com

Portugal

Mechtex Italy SRL
Tel: 0543-704597
Email : o.corsini@mechtex.com

Spain

Mechtex Italy SRL
Tel: 0543-704597
Email : o.corsini@mechtex.com.

Turkey

SANPA LTD. ŞTI
Tel: + 90-216-4780712
Email: sanpa@turk.net

United Kingdom

Motion Control Products Ltd
Tel: +44 1202 599922
Email: steve@motioncontrolproducts.com

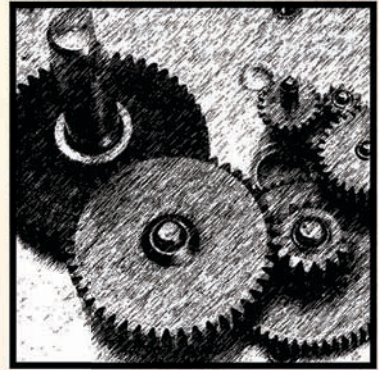
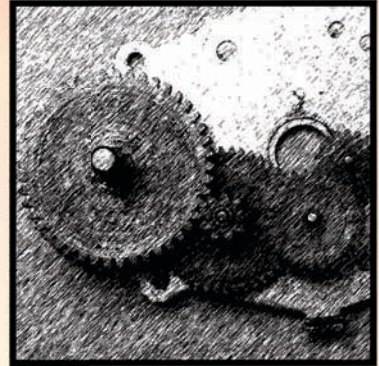
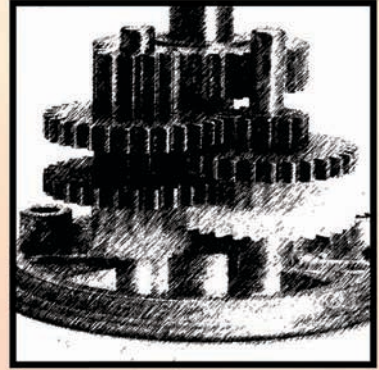

M

MOTION DRIVETRONICS PVT. LTD.

Factory Address : EL-108. Electronic Zone, Mahape TTC Indl. Estate, Navi Mumbai 400 709. Maharashtra.

Tel. : +91-22-2768 4665 / 2768 4658 Fax : +91-22-2768 4657 E-mail : info@mechtex.com

URL : www.mechtex.com

DISTRIBUTOR